

ONKYO® SERVICE MANUAL

FM STEREO/AM TUNER AMPLIFIER MODEL R-801A

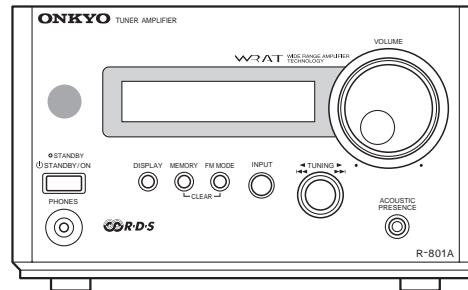

European models front panel shown.

MPP	230-240V AC, 50Hz
MDT	120V AC, 50/60Hz
MGT,MGR	220-230V,50/60Hz

SAFETY-RELATED COMPONENT WARNING!!

COMPONENTS IDENTIFIED BY MARK  ON THE SCHEMATIC DIAGRAM AND IN THE PARTS LIST ARE CRITICAL FOR RISK OF FIRE AND ELECTRIC SHOCK. REPLACE THESE COMPONENTS WITH ONKYO PARTS WHOSE PART NUMBERS APPEAR AS SHOWN IN THIS MANUAL.

MAKE LEAKAGE-CURRENT OR RESISTANCE MEASUREMENTS TO DETERMINE THAT EXPOSED PARTS ARE ACCEPTABLY INSULATED FROM THE SUPPLY CIRCUIT BEFORE RETURNING THE APPLIANCE TO THE CUSTOMER.

SPECIFICATIONS

Amplifier Section

Power output

17 watts per channel, min RMS, at 4 ohms, both channels driven 1 kHz, with no more than 0.8% THD
 13 watt per channel, min RMS, at 8 ohms, both channels driven 1 kHz, with no more than 0.8% THD
 2 X 17 watts at 4 ohms, 1 kHz, DIN
 2 X 15 watts at 6 ohms, 1 kHz, DIN
 2 X 13 watts at 8 ohms, 1 kHz, DIN
 2 X 24 watts at 4 ohms, 1 kHz, EIAJ

Dynamic power output

2 X 21 watts at 4 ohms
 2 X 14 watts at 8 ohms

Total harmonic distortion

0.8% at rated power

IM distortion

0.8% at rated power

Damping factor

20 at 8 ohms

Input Sensitivity and Impedance

TAPE, MD, CD/DVD, CDR/PC:
 150 mV, 50 kohms

Frequency and response

10 to 100 kHz ± 3 dB

Tone control

ACOUSTIC PRESENCE 1
 +4.5 dB at 41 Hz
 ACOUSTIC PRESENCE 2
 +5.5 dB at 82 Hz
 ACOUSTIC PRESENCE 3
 +6 dB at 41 Hz, + 6 dB at 82 Hz
 ACOUSTIC PRESENCE 4
 +6 dB at 41 Hz, + 6 dB at 82 Hz,
 +5 dB at 10 Hz

Signal to noise ratio

TAPE: 100 dB (IHF-A)

Muting

- 50 dB

Tuner Section

Tuning range

FM: 87.9 to 107.9 MHz (200 kHz steps)
 (U.S. & Canadian models)
 87.5 to 108.00 MHz (50 kHz steps)
 (Other area models)
 AM: 530 to 1710 kHz (10 kHz steps)
 (U.S. & Canadian models)
 522 to 1611 kHz (9 kHz steps)
 (Other area models)

Usable sensitivity

FM: Mono 11.2 dBf,
 1.0 μ V (75 ohms IHF)
 0.9 μ V (75 ohms DIN)
 Stereo 17.2 dBf,
 2.0 μ V (75 ohms IHF)
 23.0 μ V (75 ohms DIN)

AM: 30 μ V

50 dB Quieting sensitivity

FM: Mono 17.2 dBf, 2.0 μ V (75 ohms)
 Stereo 37.2 dBf, 20.0 μ V (75 ohms)

Capture ratio

FM: 2.0 dB

Image rejection ratio

FM: 40 dB (U.S. & Canadian models)
 85 dB (Other area models)
 AM: 40 dB

IF rejection ratio

FM: 90 dB
 AM: 40 dB

Signal to noise ratio

FM: Mono 73 dB, IHF
 Stereo 67 dB, IHF
 AM: 40 dB

Selectivity

FM: 50 dB DIN
 (± 300 kHz at 40 kHz Devi.)

AM Suppression Ratio

50 dB

Harmonic distortion

FM: Mono 0.2%
 Stereo 0.3%
 AM: 0.7 %

Frequency response

FM: 30 to 15,000 Hz (± 1.5 dB)

Stereo separation

FM: 45 dB at 1,000 Hz
 30 dB at 100 to 10,000 Hz

Stereo threshold

FM: 17.2 dBf, 2.0 μ V (75 ohms)

General

Clock precision

monthly error: ± 30 seconds
 (at 25 degrees Celsius)

Power supply

AC 120 V, 60 Hz
 AC 230-240 V, 50 Hz
 AC 220-230 V, 50 Hz/60 Hz

Power consumption

44 W

Dimensions (W X H X D)

155 X 94 X 285 mm
 6-1/8" X 3-1/16" X 11-1/4"

Weight

2.9 kg, 6.4 lbs

Specifications and external appearance are subject to change without notice as a result of product improvement.

SERVICE PROCEDURES

1. Replacing the fuses

 This symbol located near the fuses indicates that the fuse used is fast operating type. For continued protection against fire hazard, replace with same type fuse. For fuse rating refer to the marking adjacent to the symbol.

 Ce symbole indique que le fusible utilise est a rapide. Pour une protection permanente, n'utiliser que fusibles de meme type. Ce dernier est la qu le present symbol est appse.

CIRCUIT NO.	PART NO.	DESCRIPTION
F901	252082 or 252232 or 252266	0.315A-EAWK,Fuse <PP,GT,GR> 315MA-SE-TL250V,Fuse 315MA-SE-TL350V,Fuse
	252156 or 252250	1A-UL/T-237,Fuse<DT> 1A-T/UL-ST2,Fuse

Note: <PP>: 230-240V model only
<DT>: 220V model only
<GT>: 120V model only
<GR>: 220-230V model only

2. To initialize the unit

This device employs a microprocessor to perform various functions and operations. If interference generated by an external power supply, radio wave, or other electrical source results in accident which causes the specified operations and functions to operate abnormally.

To perform a result, please follow the procedure below.

1. Press and hold down the MEMORY button, then press the DISPLAY button.
2. Press the STANDBY/ON button.

After "clear" is displayed, the preset memory and each mode stored in the memory, such as surround, are initialized and will return to the factory setting.

3. Safety-check out

(120V model only)

After correcting the original service problem, perform the following safety check before releasing the set to the customer. Connect the insulating-resistance tester between the plug of power supply cord and screw on the back panel. Specifications: 3.3Mohm+/-10% at 500V.

4. Memory Preservation

This unit does not require memory preservation batteries. A built-in memory power back-up system preserves the contents of the memory during power failures and even when the unit is unplugged. The unit must be plugged in order to charge the back-up system.

The memory preservation period after the unit has been unplugged varies depending on climate and placement of the unit. On the average, memory contents are protected over a period of a few weeks after the last time the unit has been unplugged. This period is shorter when the unit is exposed to a highly humid climate.

PANEL VIEW FRONT PANEL

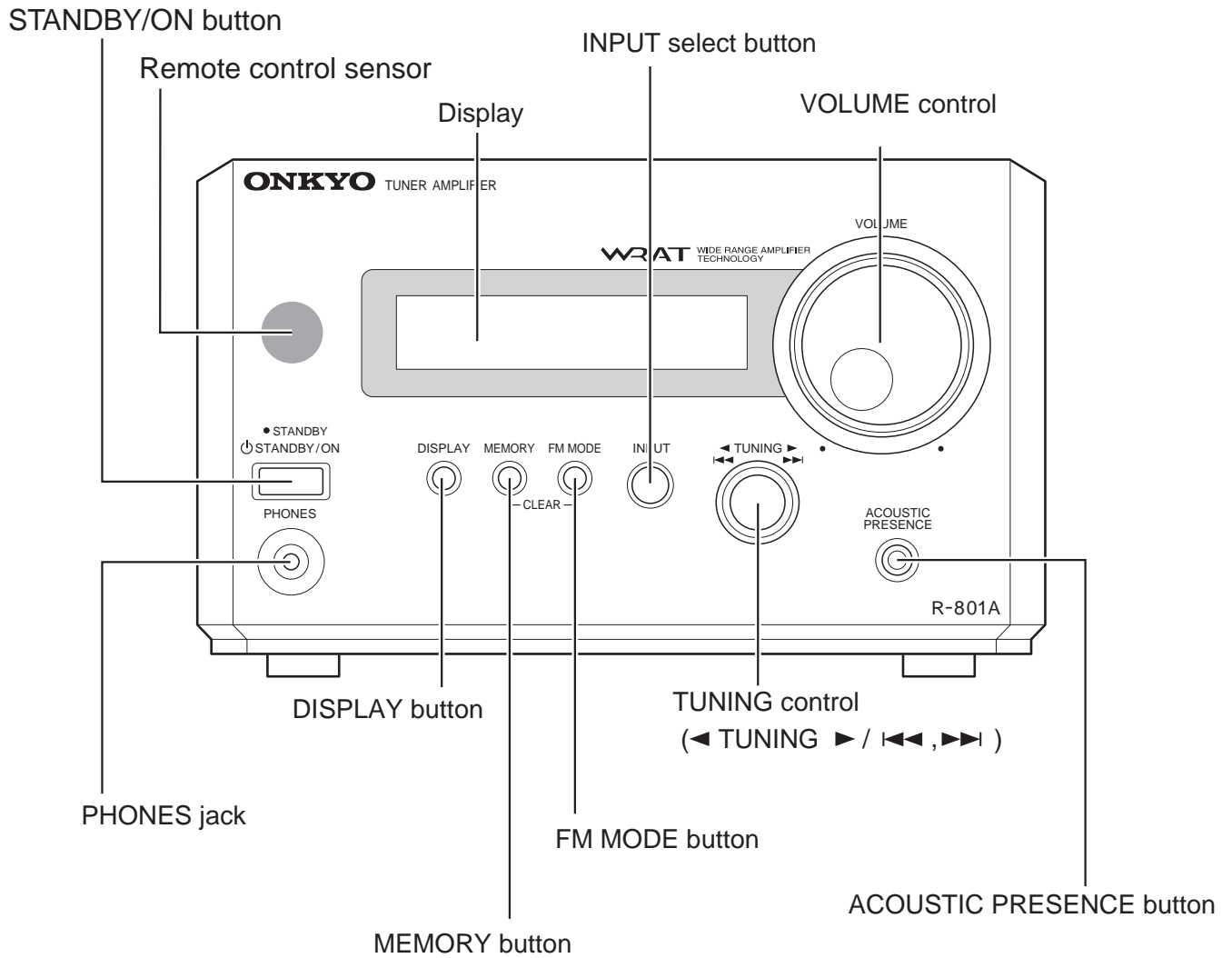

Display section

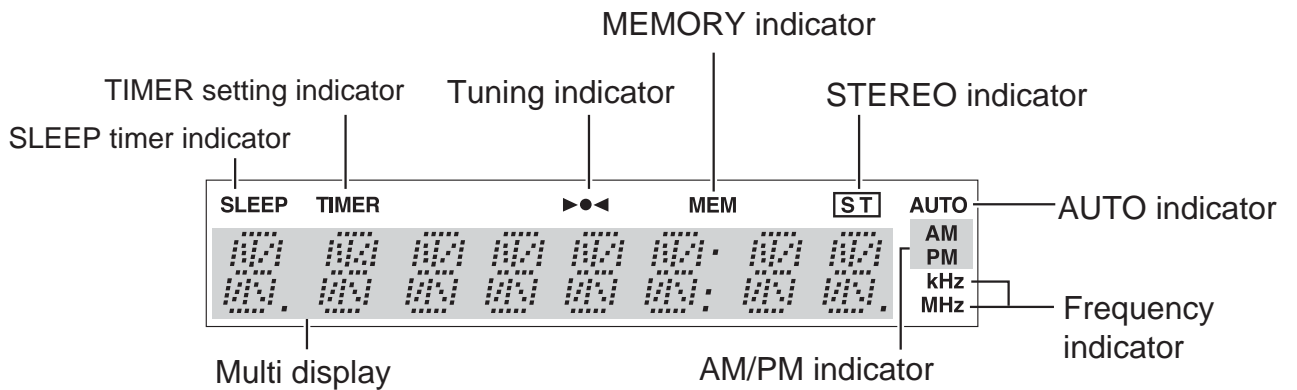

EXPLODED VIEW

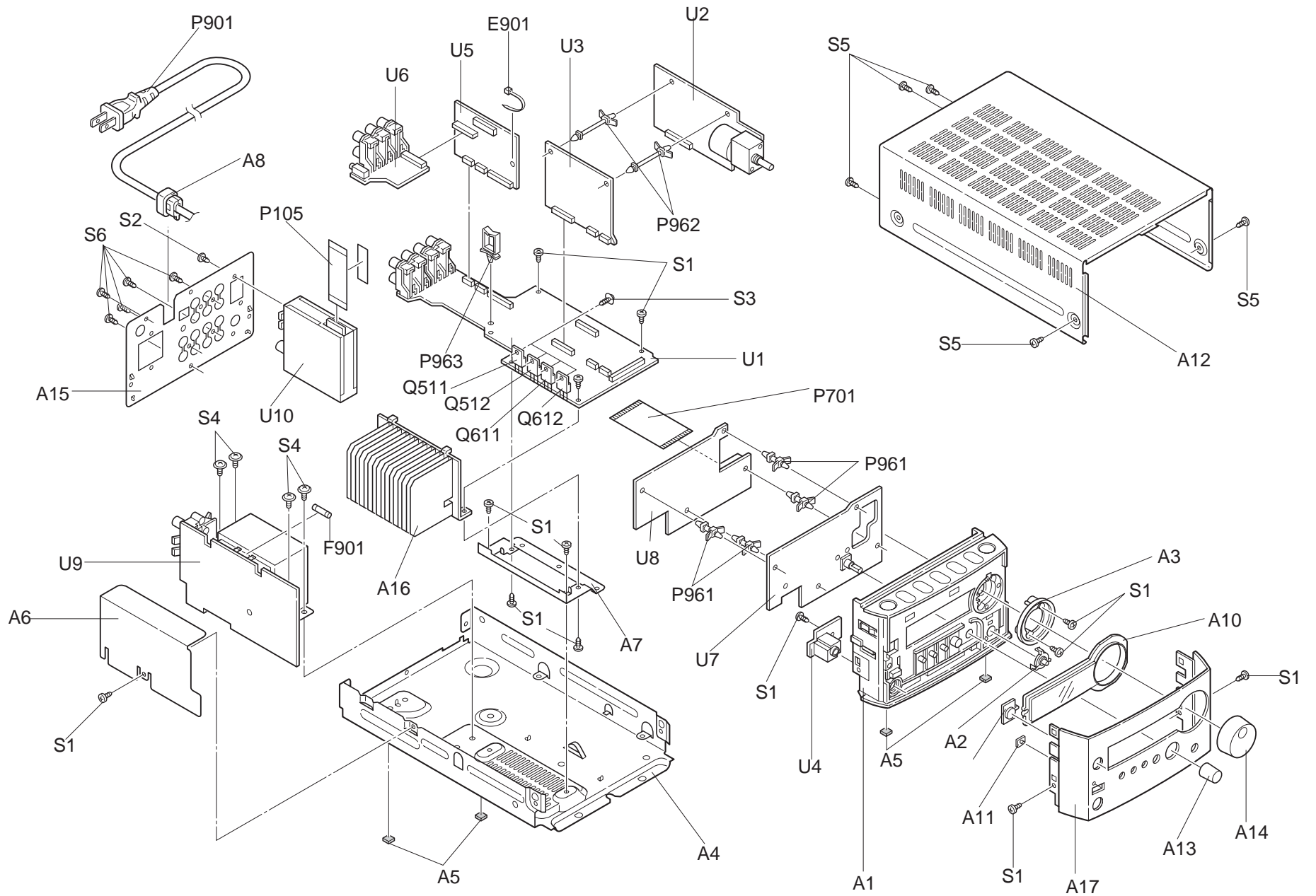

PARTS LIST

EXPLODED VIEW SECTION

REF. NO.	PART NO.	DESCRIPTION	REF. NO.	PART NO.	DESCRIPTION
A1	27111247	Front bracket	U1	1A916536-1B	NAAF-7336-1B,Main PC board <PP>
A2	28325974A	Acoustic presence ass'y,Knob		1A916536-1C	NAAF-7336-1C,Main PC board <DT>
A3	27268056	Volume,Guide		1A916536-1D	NAAF-7336-1D,Main PC board <GR>
A4	27100410	Chassis		1A916536-1E	NAAF-7336-1E,Main PC board <GT>
A5	28141489	Cushion	U2	1A916537-1B	NAAF-7337-1B,Acoustic PC board <PP>
A6	28175276	Insulation plate		1A916537-1C	NAAF-7337-1C,Acoustic PC board <DT>
A7	27130872	HT,Bracket		1A916537-1D	NAAF-7337-1D,Acoustic PC board <GR>
A8	27300750	▲ #2271,Bushing		1A916537-1E	NAAF-7337-1E,Acoustic PC board <GT>
A10	28191953	Clear plate <PP>	U3	1A916538-1B	NAAF-7338-1B,Driver PC board <PP>
	28191940	Clear plate <DT,GR,GT>		1A916538-1C	NAAF-7338-1C,Driver PC board <DT>
A11	28198938	Facet		1A916538-1D	NAAF-7338-1D,Driver PC board <GR>
A12	28184824	Cover		1A916538-1E	NAAF-7338-1E,Driver PC board <GT>
A13	28325962	Tuner,Knob	U4	1A916539-1B	NAETC-7339-1B,Headphone PC board <PP>
A14	28325963	Volume ass'y,Knob		1A916539-1C	NAETC-7339-1C,Headphone PC board <DT>
A15	27122905	Rear panel		1A916539-1D	NAETC-7339-1D,Headphone PC board <GR>
A16	27160478	RAD-147,Heat sink		1A916539-1E	NAETC-7339-1E,Headphone PC board <GT>
A17	27212348	Front panel <PP>	U5	1A916540-1B	NAETC-7340-1B,Connection PC board <PP>
	27212347	Front panel <DT,GR,GT>		1A916540-1C	NAETC-7340-1C,Connection PC board <DT>
F901	252082 or	▲ 0.315A-SE-EAWK,Fuse <PP,GR,GT>		1A916540-1D	NAETC-7340-1D,Connection PC board <GR>
	252232 or	▲ 315MA-SE-TL250V,Fuse <PP,GR,GT>		1A916540-1E	NAETC-7340-1E,Connection PC board <GT>
	252266	▲ 315MA-SE-TL250V,Fuse <PP,GR,GT>	U6	1A916541-1B	NAETC-7341-1B,Input/Output PC board <PP>
	252156 or	▲ 1A-UL/T-237,Fuse <DT>		1A916541-1C	NAETC-7341-1C,Input/Output PC board <DT>
	252250	▲ 1A-T/UL-ST2,Fuse <DT>		1A916541-1D	NAETC-7341-1D,Input/Output PC board <GR>
P901	253332HIT or	▲ AS-UC-2,Power supply cord <DT>		1A916541-1E	NAETC-7341-1E,Input/Output PC board <GT>
	253333VOL	▲ AS-UC-2,Power supply cord <DT>	U7	1A916542-1B	NADIS-7342-1B,Display PC board <PP>
	253335HIT or	▲ AS-CEE,Power supply cord <PP,GT>		1A916542-1C	NADIS-7342-1C,Display PC board <DT>
	253336VOL	▲ AS-CEE,Power supply cord <PP,GT>		1A916542-1D	NADIS-7342-1D,Display PC board <GR>
	253337HIT or	▲ AS-CCEE,Power supply cord <GR>		1A916542-1E	NADIS-7342-1E,Display PC board <GT>
	253338VOL	▲ AS-CCEE,Power supply cord <GR>	U8	1A916543-1B	NADG-7343-1B,Microprocessor PC board <PP>
Q511,Q611	2203595 or	● KTC2026-GR,Transistor		1A916543-1C	NADG-7343-1C,Microprocessor PC board <DT>
	2203383 or	● 2SC3851-O,Transistor		1A916543-1D	NADG-7343-1D,Microprocessor PC board <GR>
	2203384 or	● 2SC3851-Y,Transistor		1A916543-1E	NADG-7343-1E,Microprocessor PC board <GT>
	2203385 or	● 2SC3851-G,Transistor	U9	1A916544-1B	NAPS-7344-1B,Power supply PC board <PP>
	2203594	● KTC2026-Y,Transistor		1A916544-1C	NAPS-7344-1C,Power supply PC board <DT>
Q512,Q612	2203615 or	● KTA1046-GR,Transistor		1A916544-1D	NAPS-7344-1D,Power supply PC board <GR>
	2203393 or	● 2SA1488-O,Transistor		1A916544-1E	NAPS-7344-1E,Power supply PC board <GT>
	2203394 or	● 2SA1488-Y,Transistor	U10	240135 or	TFCE1E512A
	2203395 or	● 2SA1488-G,Transistor		240139A	ENG07501QR
	2203614	● KTA1046-Y,Transistor			
S1	838130088	3TTB+8B,Self tapping screw			
S2	838430068	3TTB+6B(BC),Self tapping screw			
S3	801433	3SMS8W.SW+14B(BC),Self tapping screw			
S4	830440069	4TTC+6C(BC),Self tapping screw			
S5	838930088	3TTB+8B(UN),Self tapping screw			
T901	2301558	▲ NPT-1427P,Power transformer <PP>			
	2301557	▲ NPT-1427D,Power transformer <DT>			
	2301559	▲ NPT-1427G,Power transformer <GR,GT>			
E901	260208	BINDER(CLAMPER)UL			
P105	2047150512	NCFC7-150512,FFC			
P701	2047270512	NCFC7-270512,FFC			
P961	27190011	KGLS-6S,Holder			
P962	27190470	HOLDER KGLS-18S,Holder			

CAUTION:

Replacement for transistor of mark ●, if necessary must be made from the same beta group (hFE) as the original type.

Note
<PP>.....European model only
<DT>.....120V model only
<GT,GR>...220-230V model only
THE COMPONENTS IDENTIFIED BY MARK ▲ ARE CRITICAL FOR RISK OF FIRE AND ELECTRIC SHOCK. REPLACE ONLY WITH PART NUMBER SPECIFIED.

SCHEMATIC DIAGRAM 3

NADIS-7342

U7 Display PC board

NADG-7343

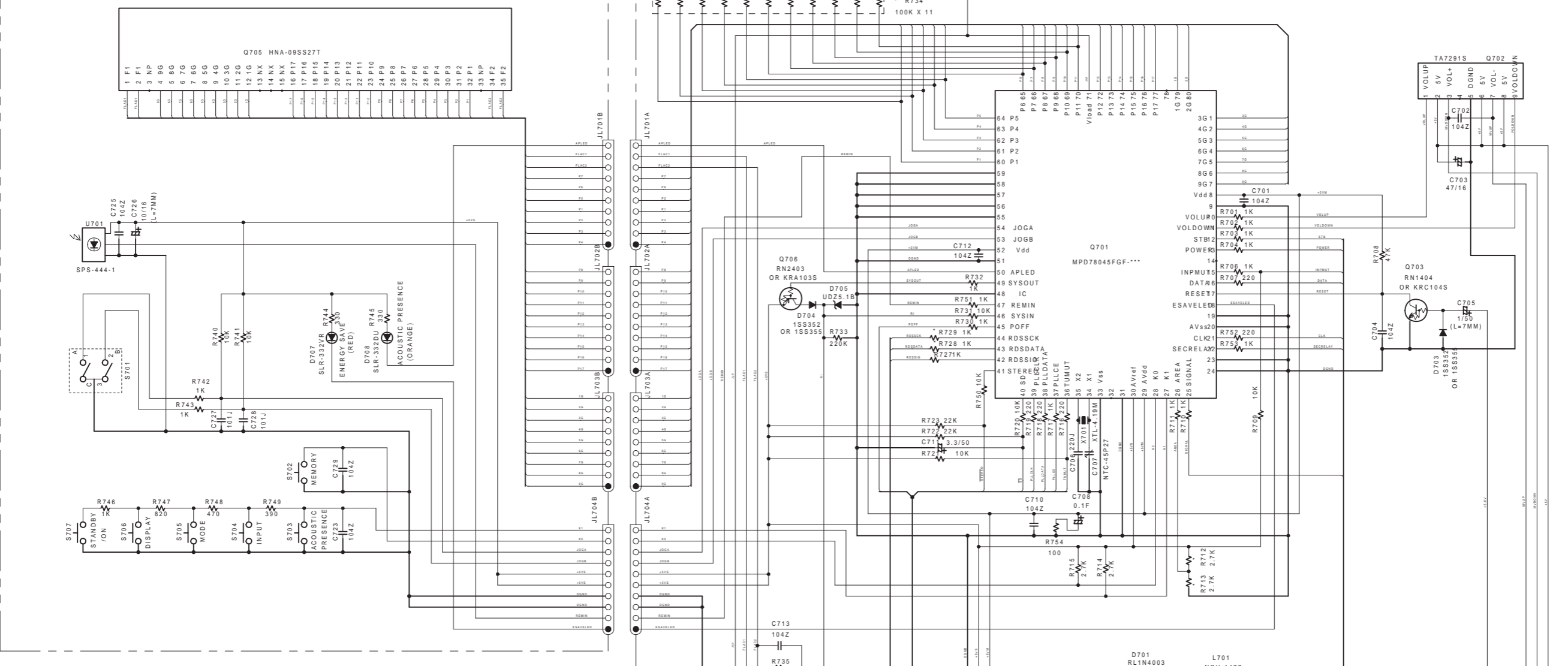

NADG-7343

	RDS	R712	R713	R734
MJJ	NO	NO	10K	ONLY OTP
MPP	YES	10K	NO	ONLY OTP
MDT	NO	5.6K	3.3K	ONLY OTP
MGT	NO	5.6K	3.3K	ONLY OTP
MGR	NO	5.6K	3.3K	ONLY OTP

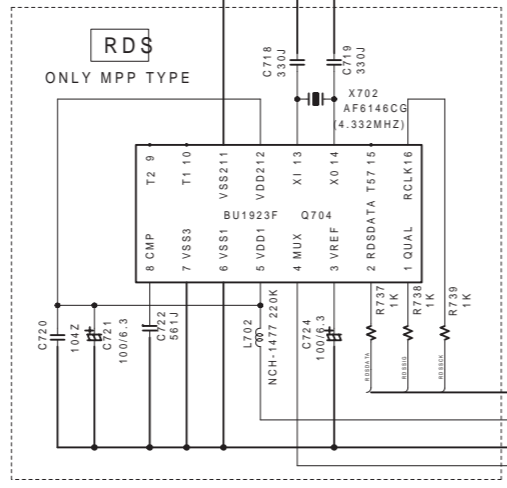

U8 Microprocessor PC board

NOTE

THE COMPONENTS IDENTIFIED BY MARKING ARE CRITICAL FOR SAFETY. REPLACEMENT PART NUMBERS SPECIFIED ARE VOLTAGE MEASURED WITH VOLTMETER. ALL PNP TRANSISTORS ARE EQUIVALENT TO 2N4115-OR UNLESS OTHERWISE NOTED. ALL NPN TRANSISTORS ARE EQUIVALENT TO 2N3181-OR UNLESS OTHERWISE NOTED. ALL DIODES ARE EQUIVALENT TO 1S833 UNLESS OTHERWISE NOTED. ELECTROLYTIC CAPACITORS ARE IN μ F/WH. ALL CAPACITORS ARE IN pF/WHY UNLESS OTHERWISE NOTED. ESD: 300-RUF 300-R30F 331-R30F 3320-R30F. ALL RESISTORS ARE IN OHMS $\frac{1}{4}$ WATTS UNLESS OTHERWISE NOTED. THE THICK LINES ON PC BOARD ARE THE PRINTING SIDE OF THE PARTS. PRINTING SIDE. CIRCUIT IS SUBJECT TO CHANGE FOR IMPROVEMENT.

SCHEMATIC DIAGRAM 2

U2 Acoustic PC board

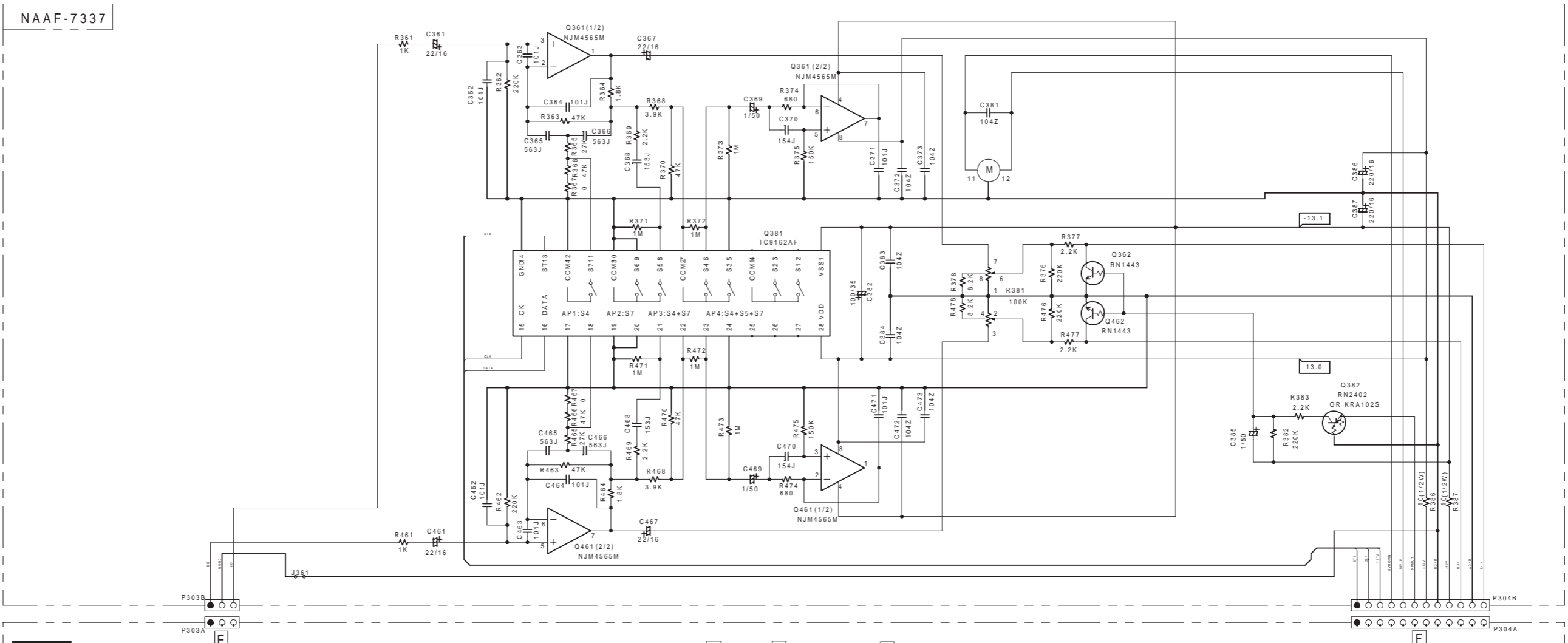

U1 Main PC board

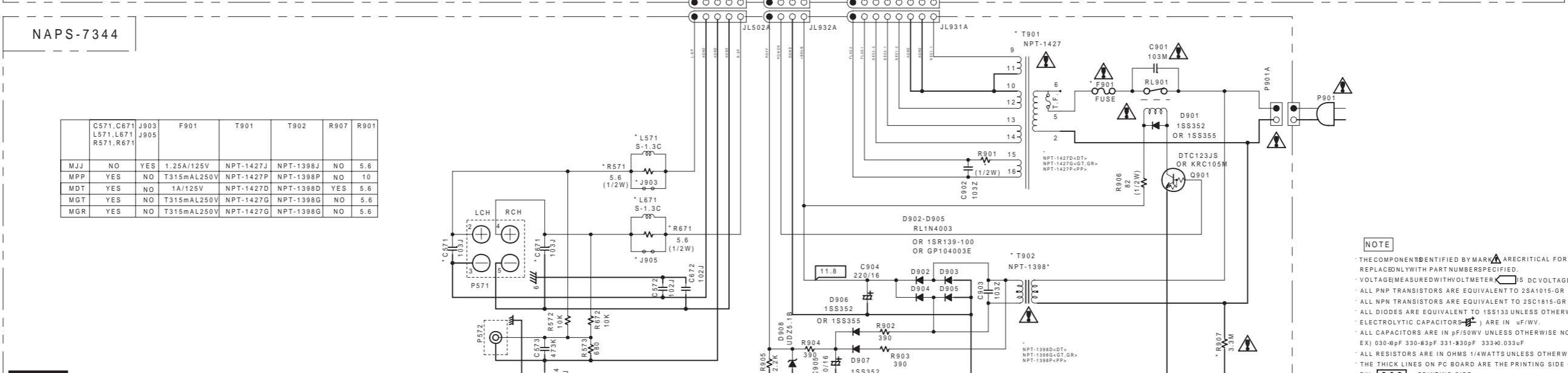

U9 Power supply circuit PC board



NOTE

- THE COMPONENT IDENTIFIED BY MARK ARE CRITICAL FOR SAFETY. REPLACED ONLY WITH PART NUMBERS SPECIFIED.
- VOLTAGE MEASURED WITH VOLTMETER IS DC VOLTAGE (NO INPUT SIGNAL).
- ALL PNP TRANSISTORS ARE EQUIVALENT TO 2SA1015-GR UNLESS OTHERWISE NOTED.
- ALL NPN TRANSISTORS ARE EQUIVALENT TO 2SC1815-GR UNLESS OTHERWISE NOTED.
- ALL DIODES ARE EQUIVALENT TO 1SS133 UNLESS OTHERWISE NOTED.
- ELECTROLYTIC CAPACITORS ARE IN μ F/VV.
- ALL CAPACITORS ARE IN pF/50V UNLESS OTHERWISE NOTED.
- EX) 030-8pF 330-83pF 331-830pF 333-0.033uF
- ALL RESISTORS ARE IN OHMS 1/4WATTS UNLESS OTHERWISE NOTED.
- THE THICK LINES ON PC BOARD ARE THE PRINTING SIDE OF THE PARTS.
- EX) PRINTING SIDE
- CIRCUIT IS SUBJECT TO CHANGE FOR IMPROVEMENT.

SCHEMATIC DIAGRAM 1

U2 Acoustic PC board

U3 Driver PC board

U4 Headphone PC board

U1 Main PC board

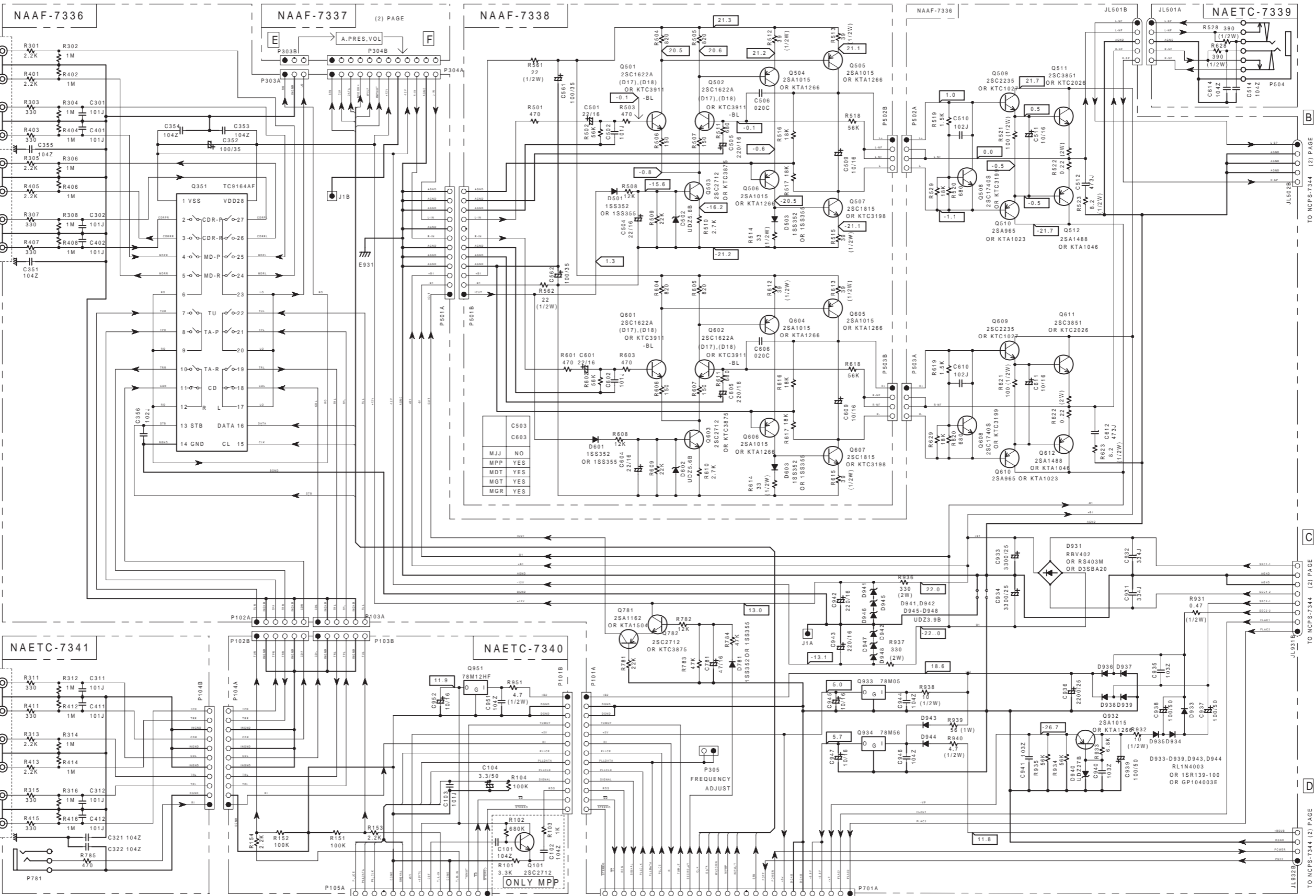

NOTE

THE COMPONENT IDENTIFIED BY MARK IS CRITICAL FOR SAFETY. REPLACEMENT PART NUMBER SPECIFIED.

VOLTAGE MEASURED WITH MULTIMETER. IS DC VOLTAGE (INPUT SIGNAL).

ALL PNP TRANSISTORS ARE EQUIVALENT TO 2SA1015-GR UNLESS OTHERWISE NOTED.

ALL NPN TRANSISTORS ARE EQUIVALENT TO 2SC1622A-GR UNLESS OTHERWISE NOTED.

ALL DIODES ARE EQUIVALENT TO 1SS133 UNLESS OTHERWISE NOTED.

ELECTROLYTIC CAPACITORS ARE IN μ F/VOL.

ALL CAPACITORS ARE IN pF/50V UNLESS OTHERWISE NOTED.

EX) 500-50P 330-50P 101-100P 333M-033P

ALL RESISTORS ARE IN OHMS Ω UNLESS OTHERWISE NOTED.

THE THICK LINES ON PC BOARD ARE THE PRINTING SIDE OF THE PARTS.

EX) PRINTING SIDE.

CIRCUIT IS SUBJECT TO CHANGE FOR IMPROVEMENT.

U6 Input/Output PC board

U5 Connection PC board

TO TUNER PACK

RIGHT TO NCDG-7343 (3) PAGE

TO NCPFS-7344 (2) PAGE

TO NCPFS-7344 (2) PAGE

TO NCPFS-7344 (2) PAGE

TO NCPFS-7344 (2) PAGE

TO NCPFS-7344 (2) PAGE

TO NCPFS-7344 (2) PAGE

1

2

3

4

5

SCHEMATIC DIAGRAM 1-2

U3 Driver PC board

U1 Main PC board

U4 Headphone PC board

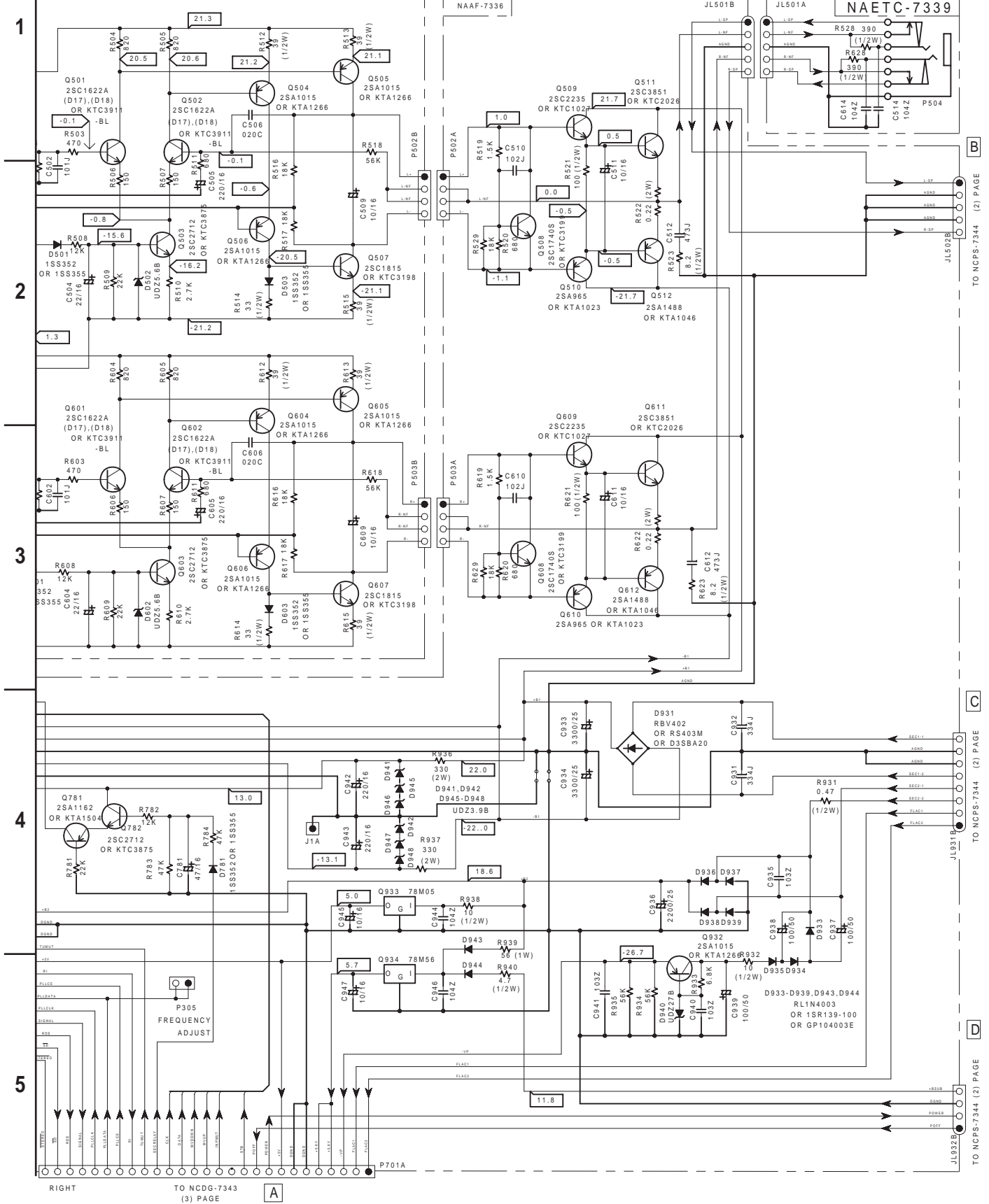

TO NCPS-7344 (2) PAGE

TO NCPS-7344 (2) PAGE

TO NCPS-7344 (2) PAGE

SHEMATIC DIAGRAM 1-1

U3

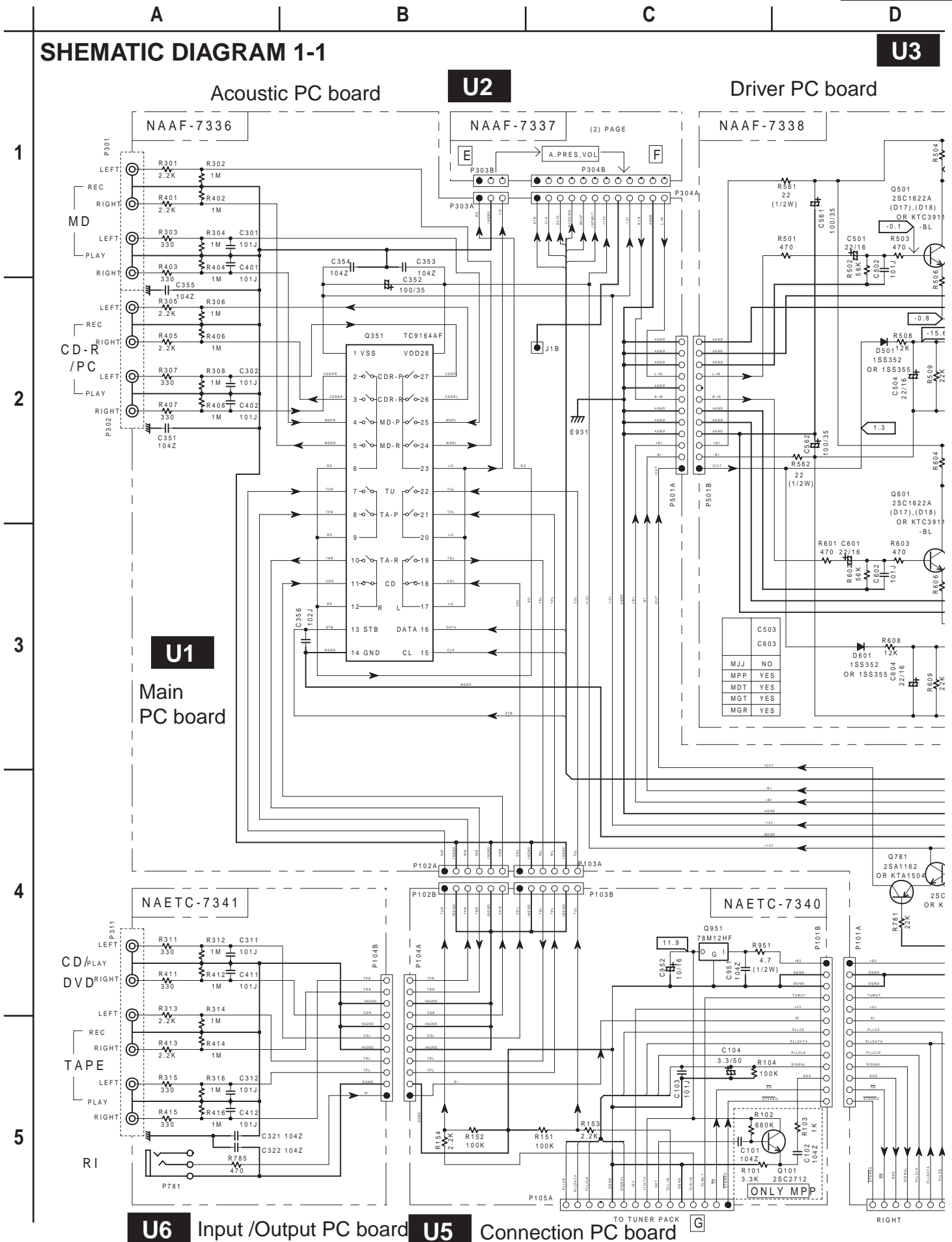

U6 Input /Output PC board

U5 Connection PC board

TO TUNER PACK G

A B C D
SCHEMATIC DIAGRAM 2-2

1

2

3

U2
Acoustic PC board

U1 Main PC board

4

5

U9 Power supply PC board

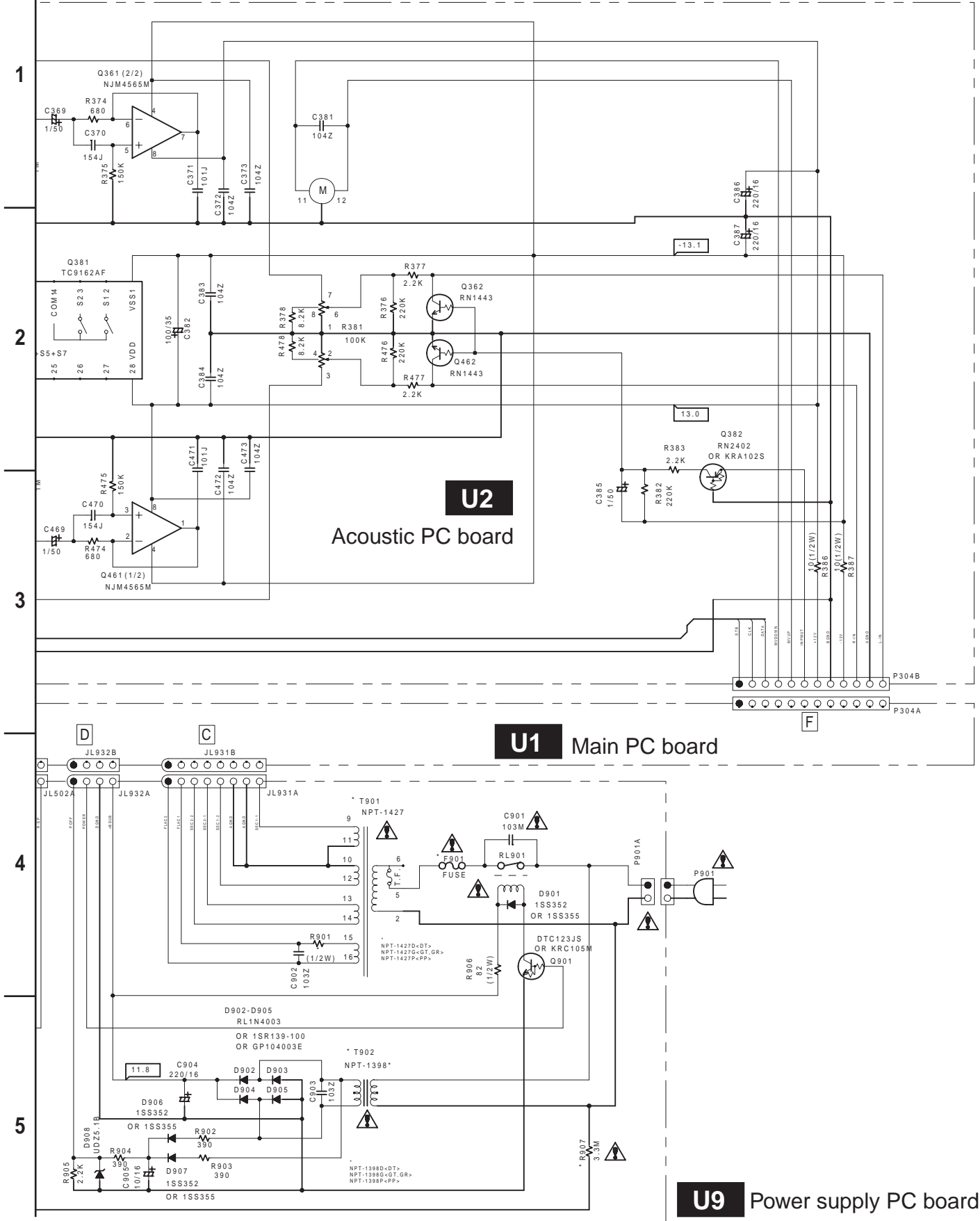

A B C D

SCHEMATIC DIAGRAM 2-1

U2 Acoustic PC board

NAAF-7337

1

2

3

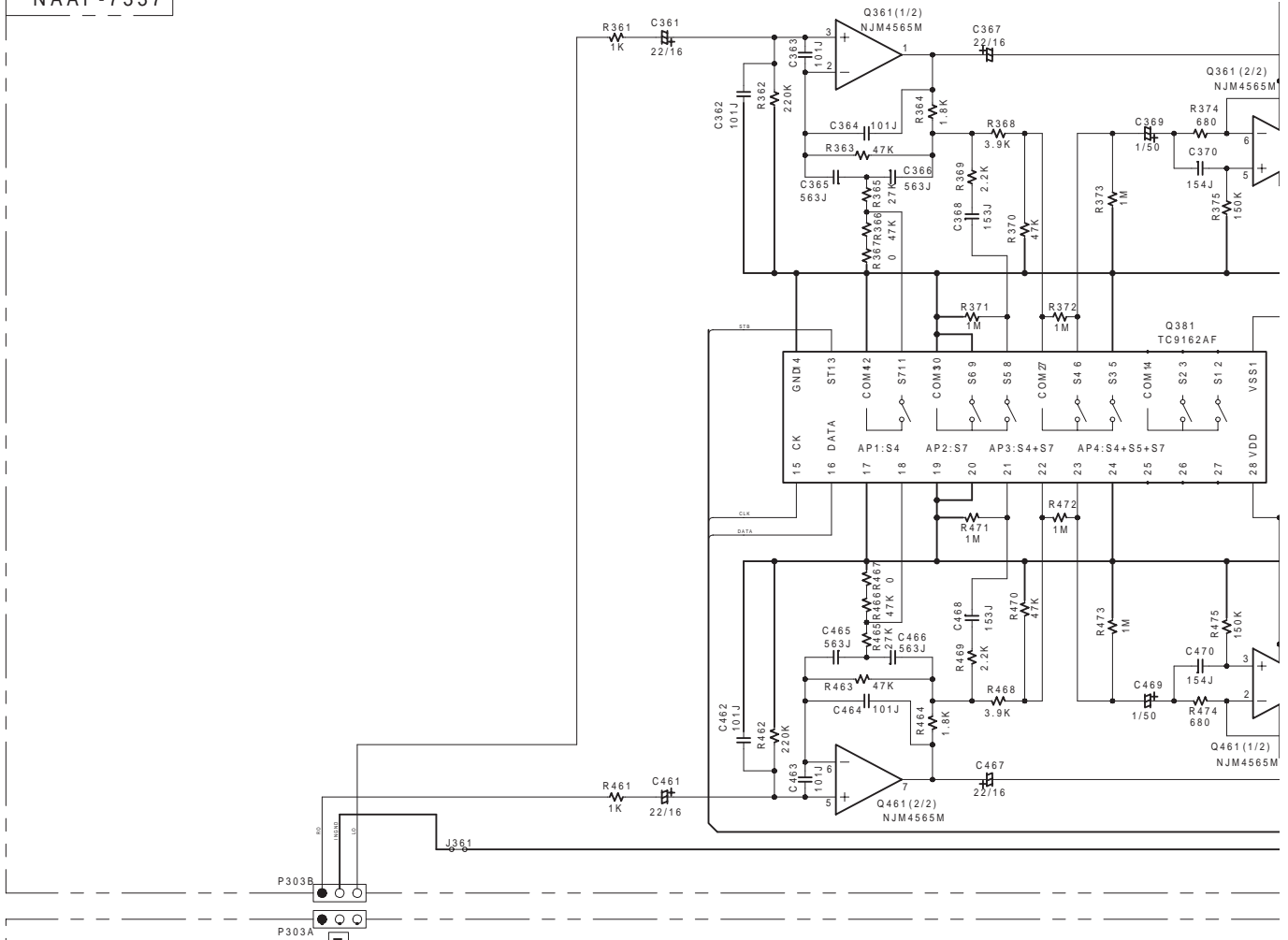

U1 Main PC board

NCAF-7336

(1) PAGE

NAPS-7344

4

	C571, C671 L571, L671 R571, R671	J903 J905	F901	T901	T902	R907	R901
MJJ	NO	YES	1.25A/125V	NPT-1427J	NPT-1398J	NO	5.6
MPP	YES	NO	T315mAL250V	NPT-1427P	NPT-1398P	NO	10
MDT	YES	NO	1A/125V	NPT-1427D	NPT-1398D	YES	5.6
MGT	YES	NO	T315mAL250V	NPT-1427G	NPT-1398G	NO	5.6
MGR	YES	NO	T315mAL250V	NPT-1427G	NPT-1398G	NO	5.6

5

U9 Power supply PC board

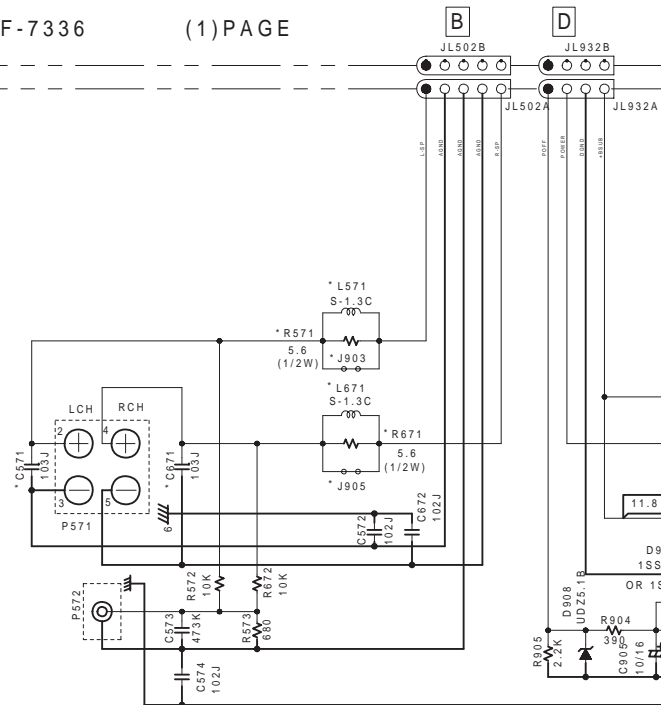

A B C D
SCHEMATIC DIAGRAM 3-2

U8

Microprocessor PC board

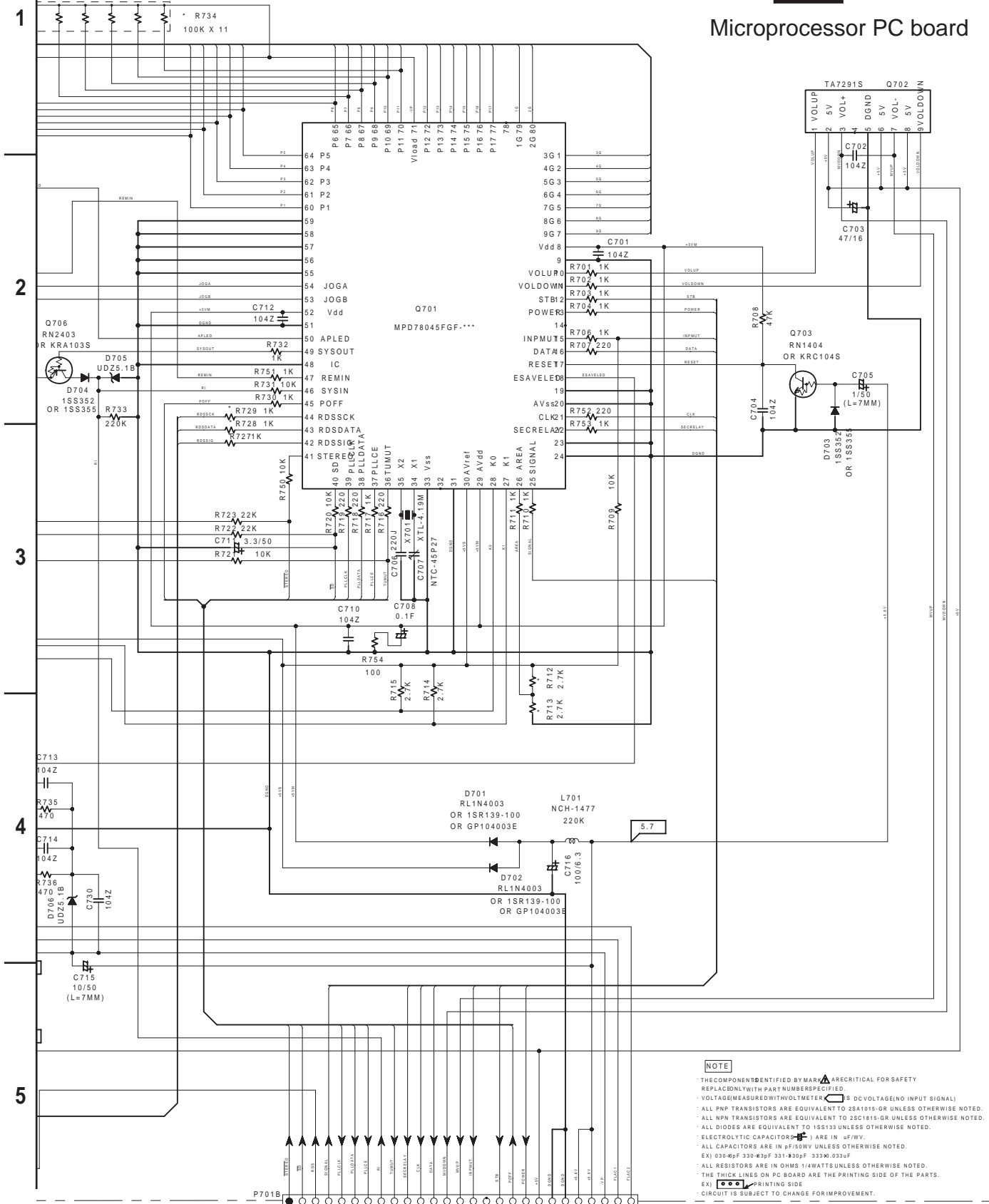

NOTE

- THE COMPONENT IDENTIFIED BY MARKING ARE CRITICAL FOR SAFETY REPLACEMENT ONLY WITH PART NUMBER SPECIFIED.
- VOLTAGE (MEASURED WITH VOLT METER) IS DC VOLTAGE (NO INPUT SIGNAL)
- ALL PNP TRANSISTORS ARE EQUIVALENT TO 2SA1015-GR UNLESS OTHERWISE NOTED.
- ALL NPN TRANSISTORS ARE EQUIVALENT TO 2SC1815-GR UNLESS OTHERWISE NOTED.
- ALL DIODES ARE EQUIVALENT TO 1SS133 UNLESS OTHERWISE NOTED.
- ELECTROLYTIC CAPACITORS ARE IN μ F/WV.
- ALL CAPACITORS ARE IN pF/50V UNLESS OTHERWISE NOTED.
- EX) 030 μ F 330 μ F 331 μ F 330 μ F 3330 μ F 033 μ F
- ALL RESISTORS ARE IN OHMS Ω WATTS UNLESS OTHERWISE NOTED.
- THE THICK LINES ON PC BOARD ARE THE PRINTING SIDE OF THE PARTS.
- EX) PRINTING SIDE
- CIRCUIT IS SUBJECT TO CHANGE FOR IMPROVEMENT.

SCHEMATIC DIAGRAM 3-1

NADIS-7342

U7 Display PC board

NADG-7343

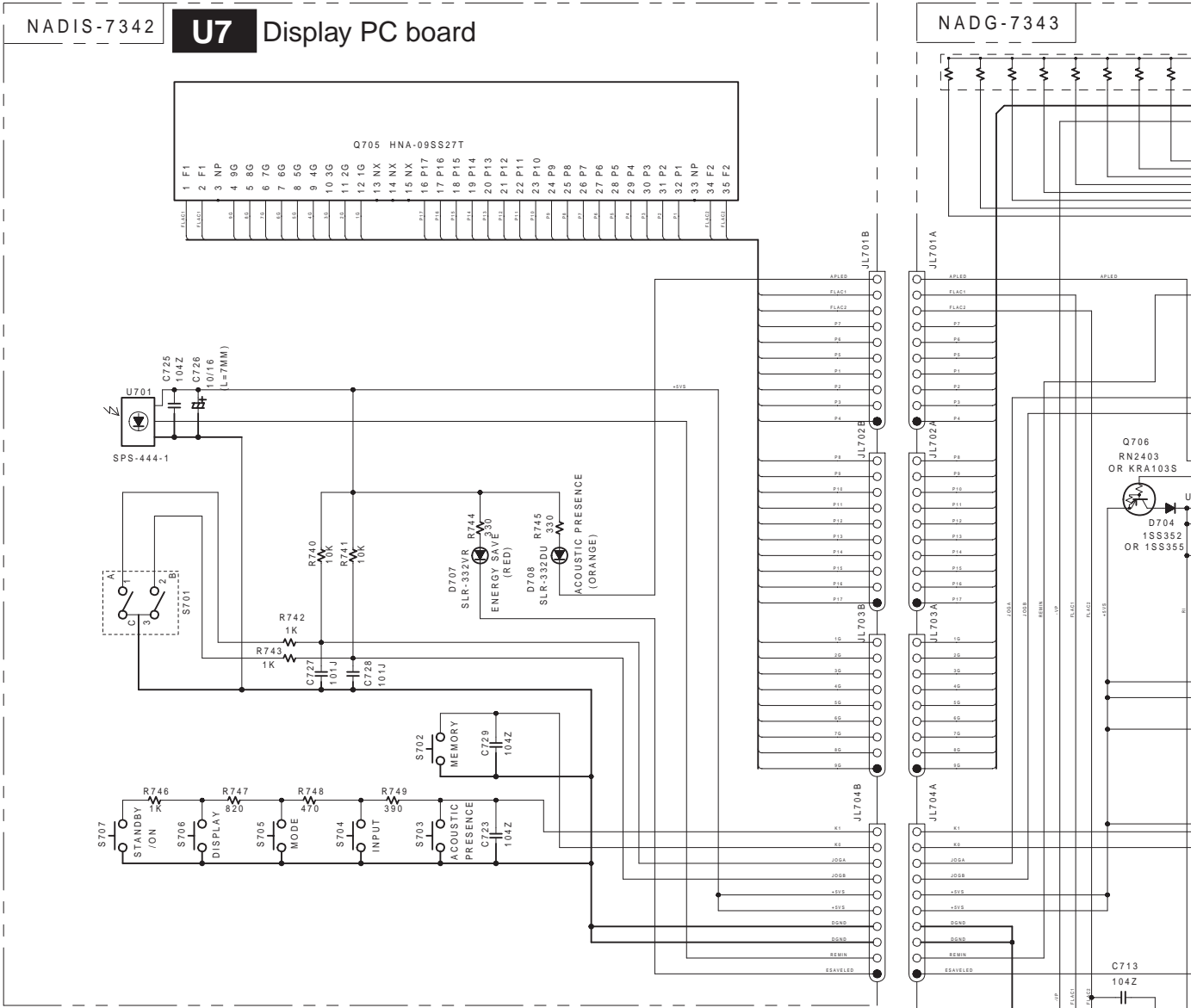

NADG-7343

	RDS	R712	R713	R734
MJJ	NO	NO	10K	ONLY OTP
MPP	YES	10K	NO	ONLY OTP
MDT	NO	5.6K	3.3K	ONLY OTP
MGT	NO	5.6K	3.3K	ONLY OTP
MGR	NO	5.6K	3.3K	ONLY OTP

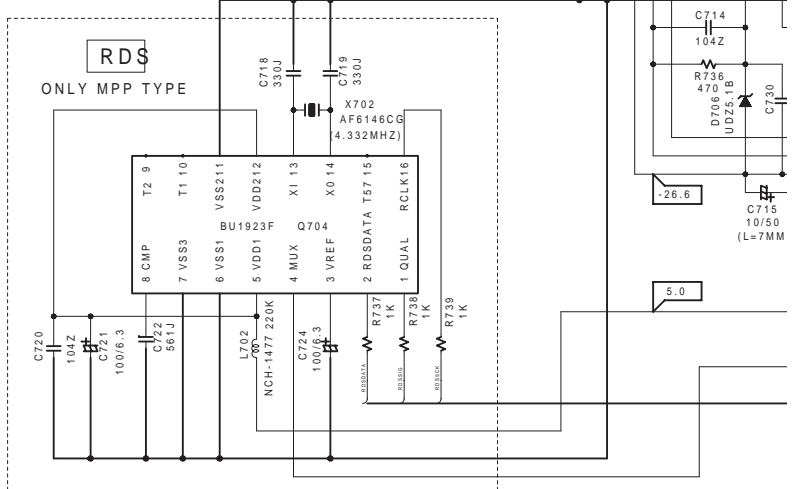

U8 Microprocessor PC board

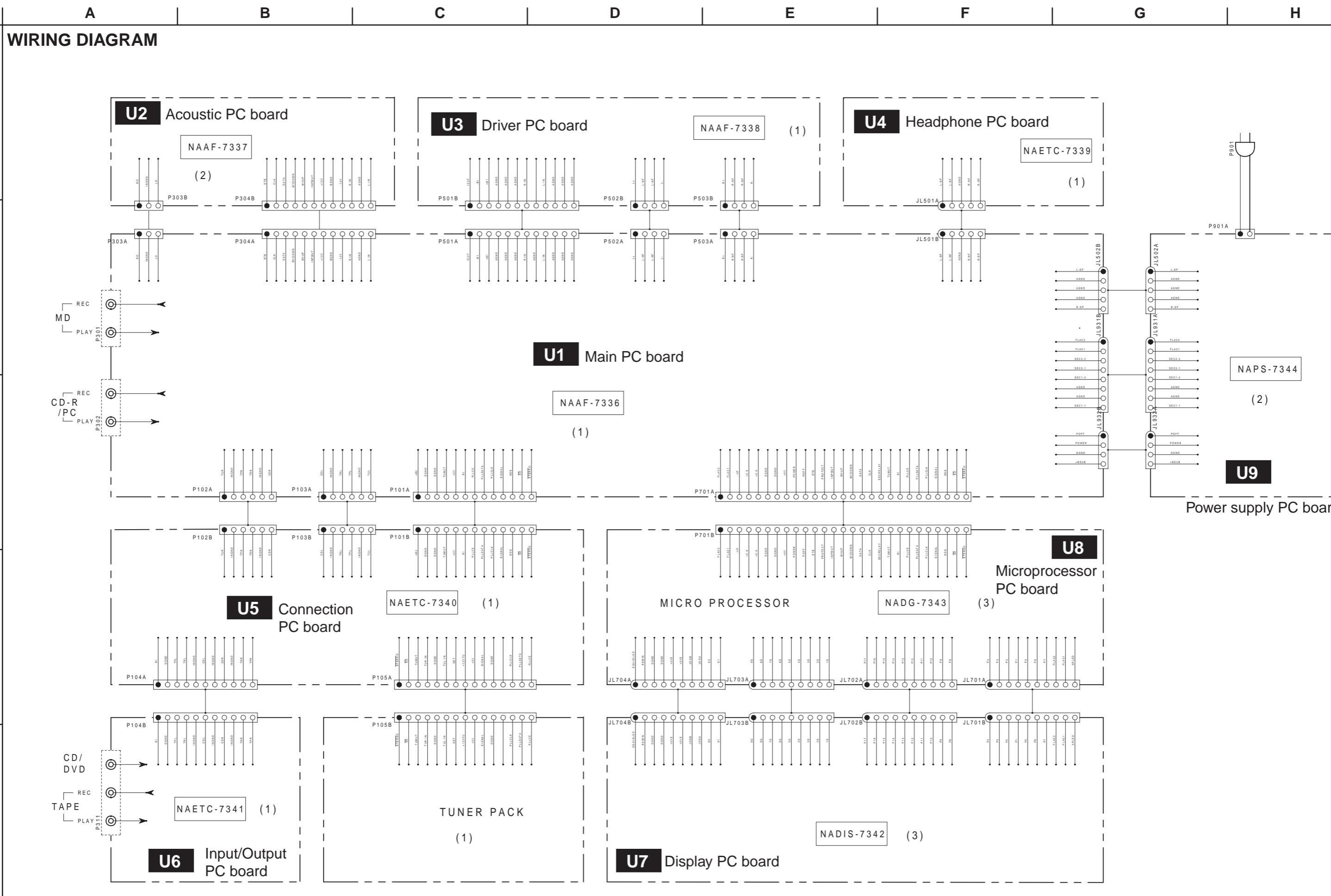

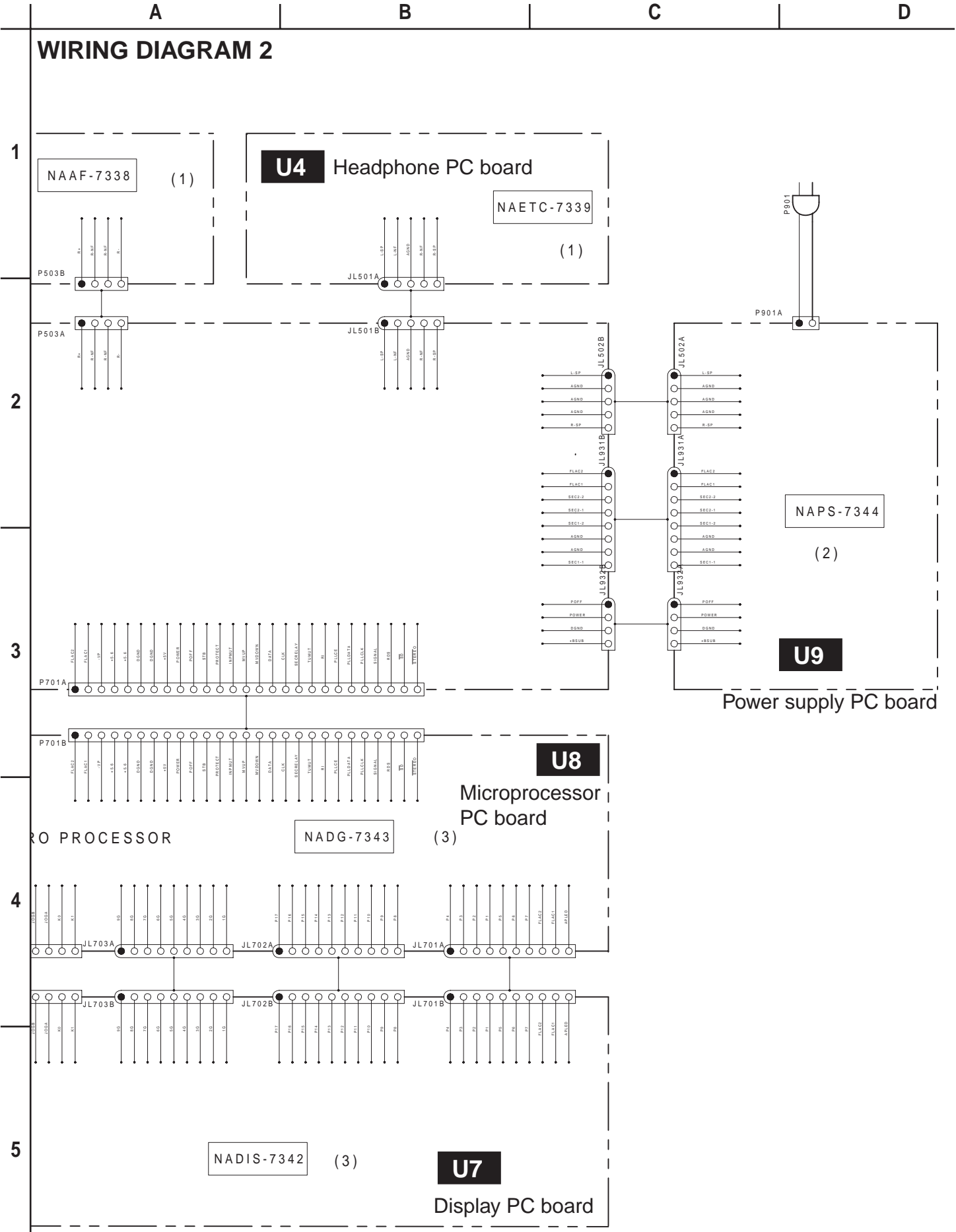

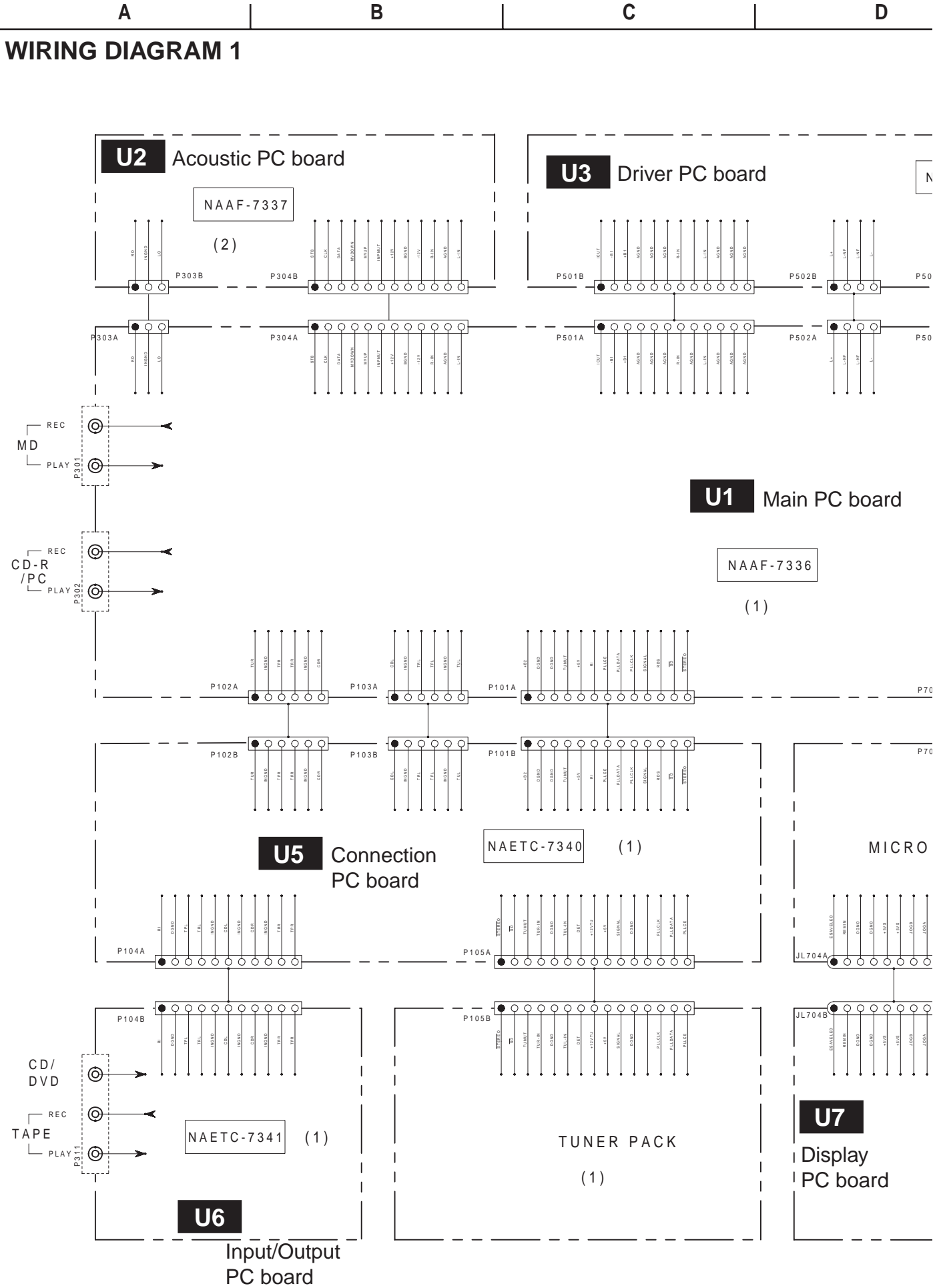

A B C D

PRINTED CIRCUIT BOARD FROM SOLDERING SIDE 1-2

U2 Acoustic PC board
NAAF-7337

U4
Headphone
PC board
NAETC-7339

1

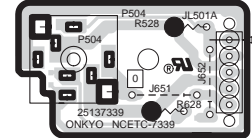
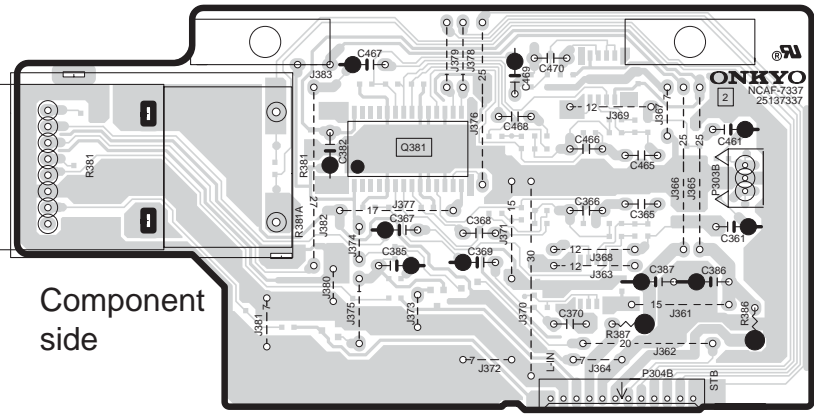

2

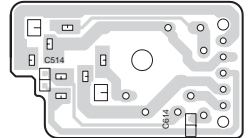
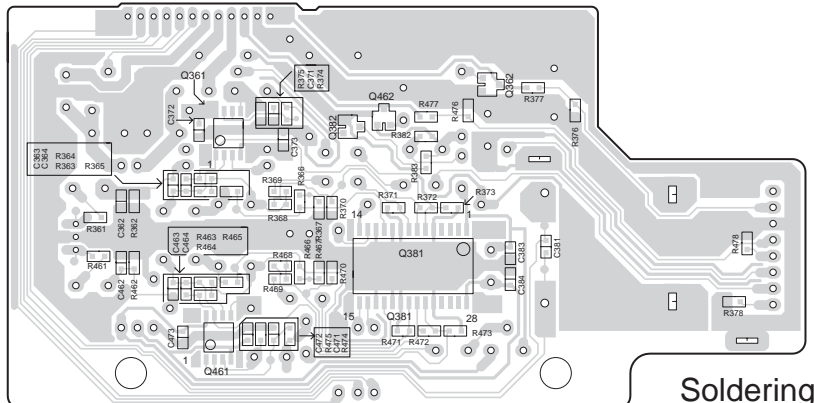

3

U3 Driver PC board
NAAF-7338

4

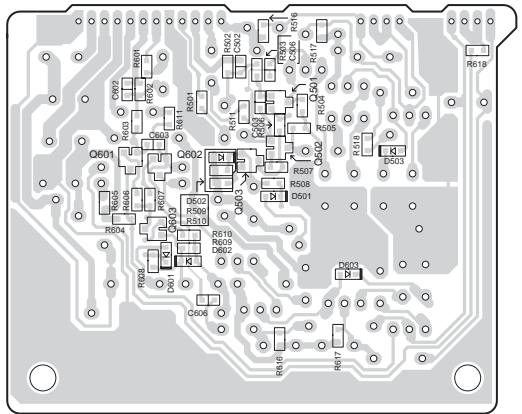
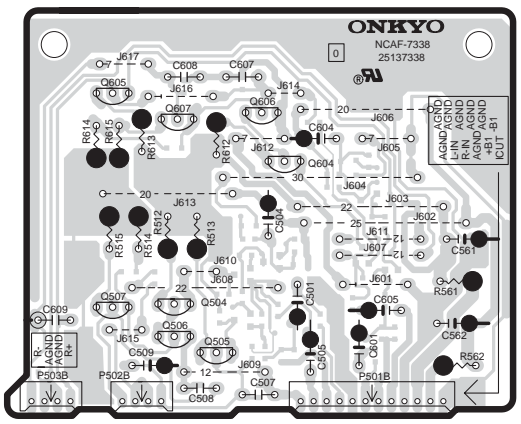

5

A B C D
PRINTED CIRCUIT BOARD FROM SOLDERING SIDE 1-1

1

U1 Main PC board
NAAF-7336

2

Soldering side

3

4

5

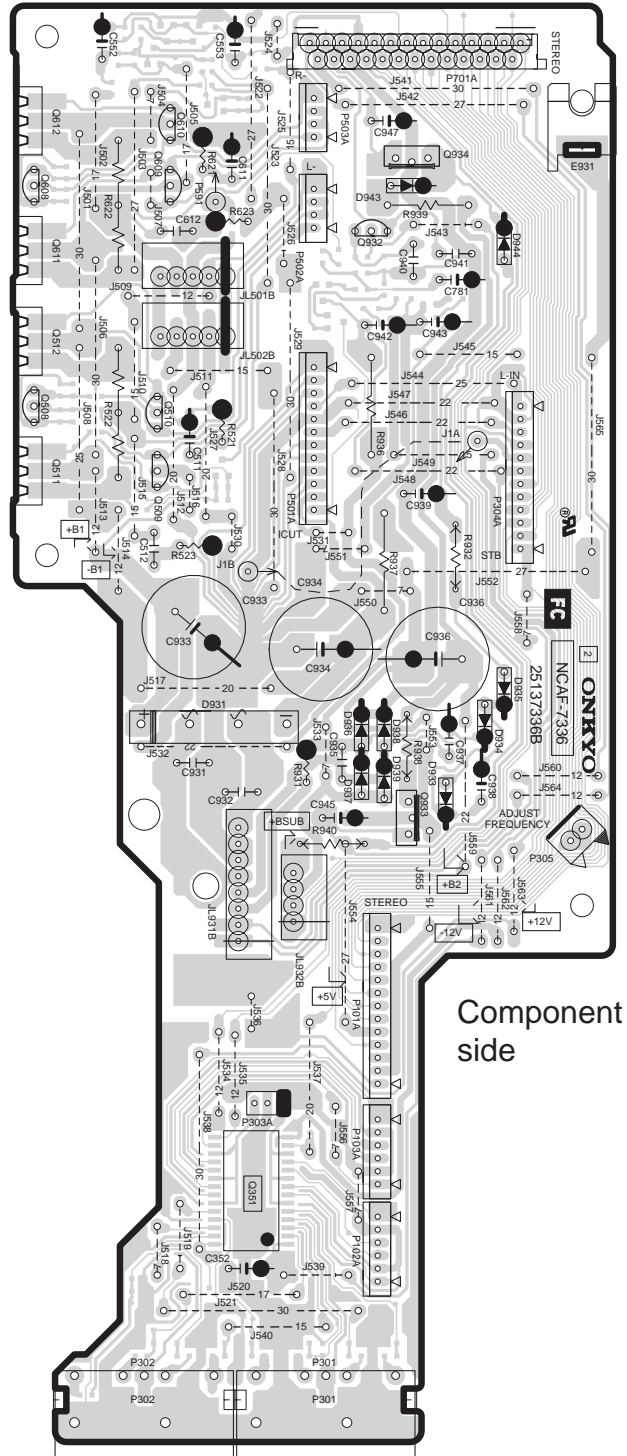
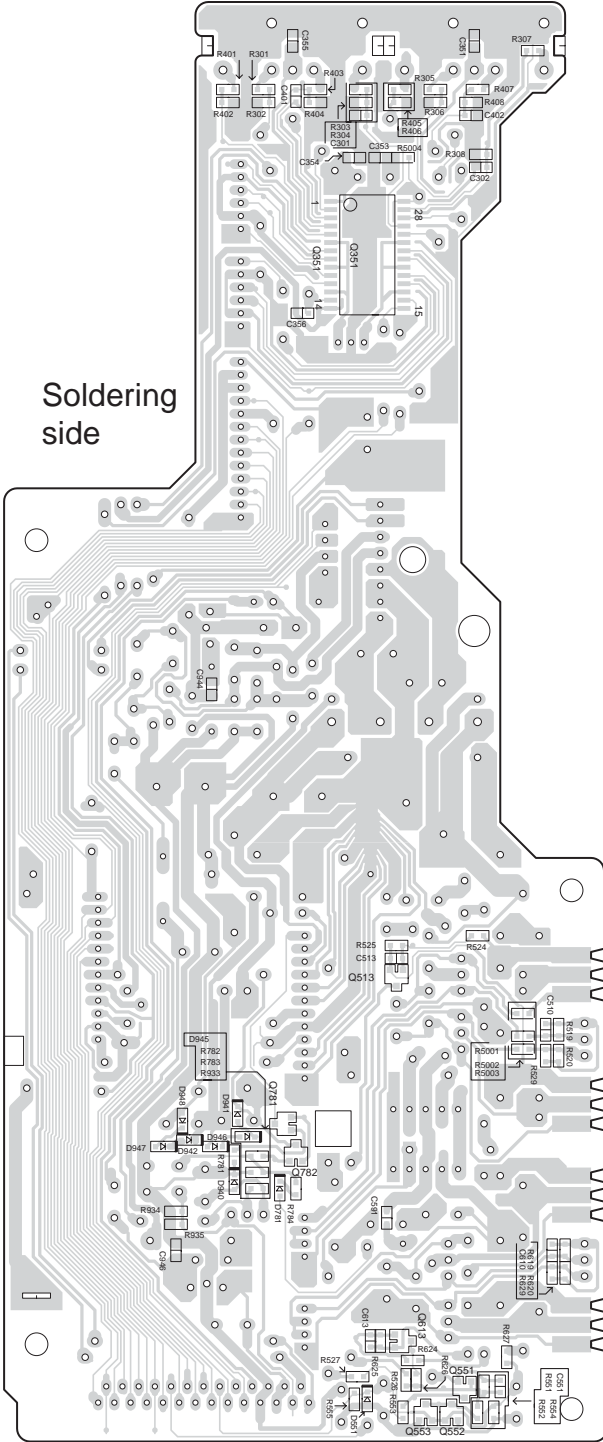

Component side

A B C D
PRINTED CIRCUIT BOARD FROM SOLDERING SIDE 2-2

1

U8

Microprocessor
PC board
NADG-7343

Soldering
side

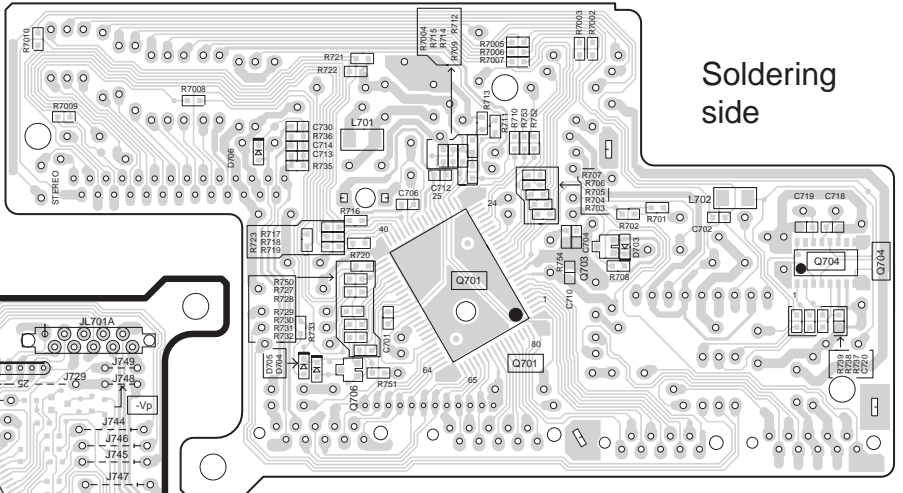

2

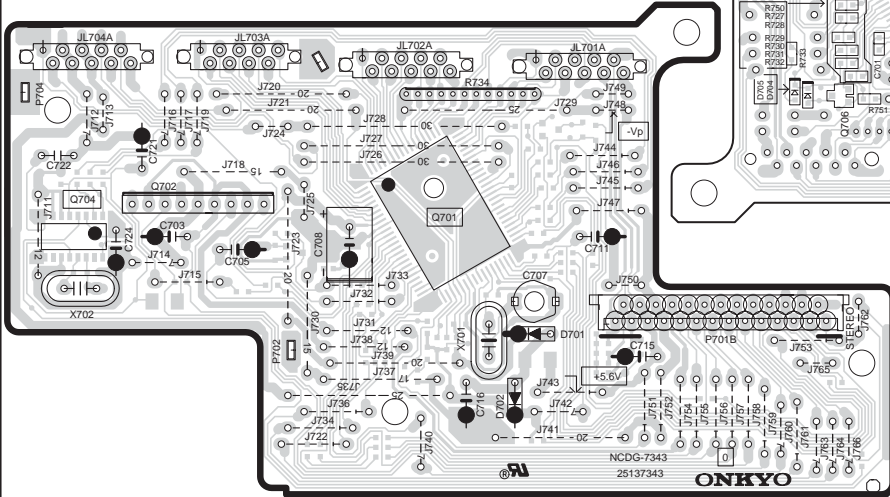

Component side

3

U9

Power supply
PC board
NAPS-7344

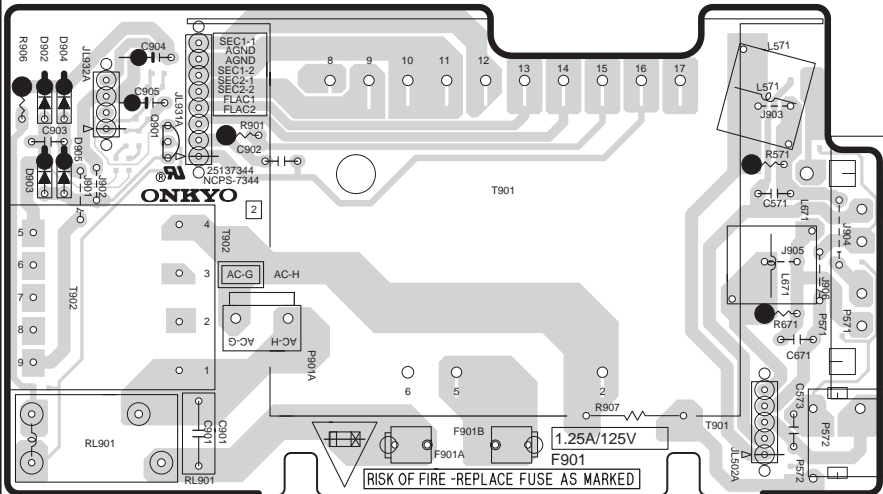

4

Component side

5

Soldering
side

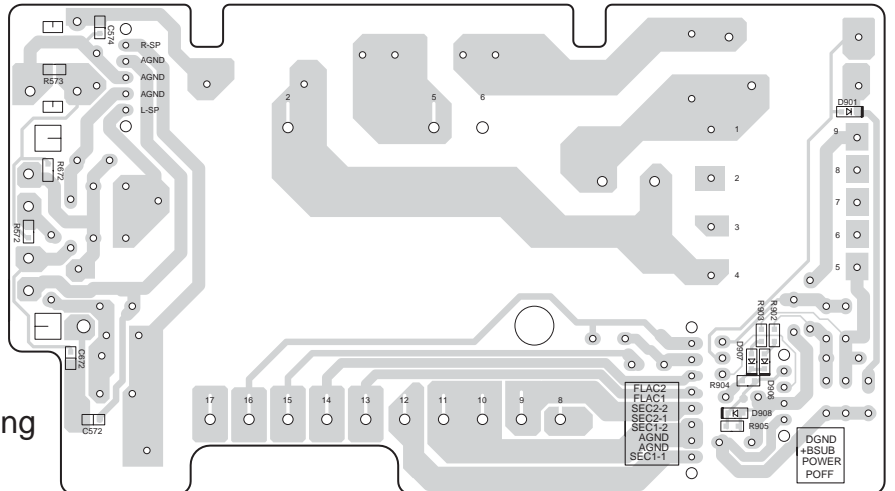

PRINTED CIRCUIT BOARD FROM SOLDERING SIDE 2-1

1

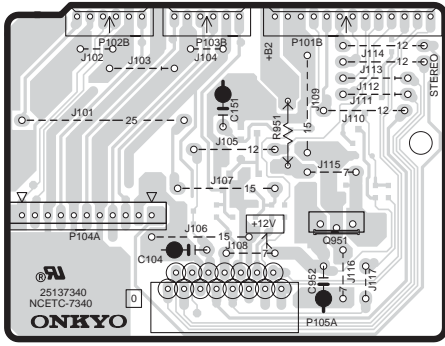

U5

Connection PC board
NAETC-7340

Component side

Soldering side

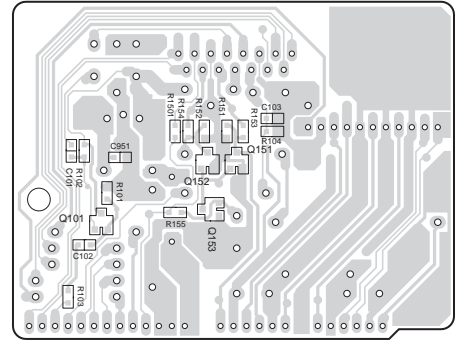

2

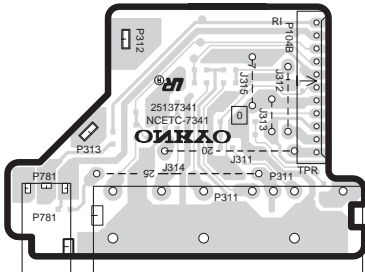

U6

Input/Output
PC board
NAETC-7341

Component side

Soldering side

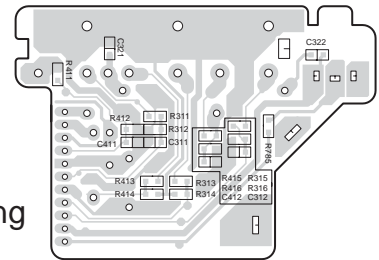

3

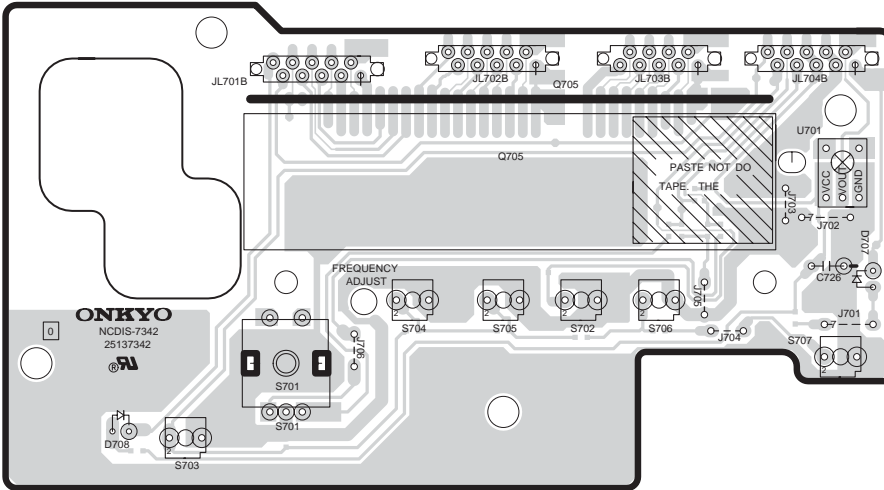

U7

Display PC board
NADIS-7342

Component side

5

Soldering side

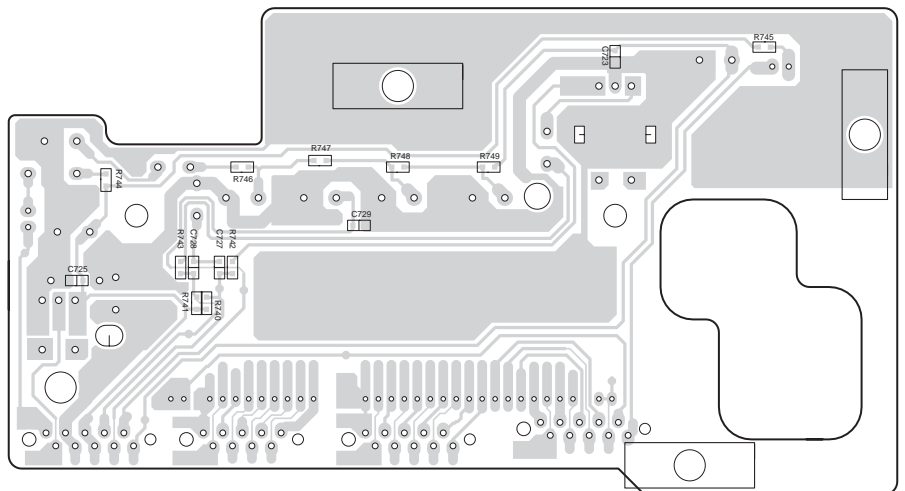

PARTS LIST

CIRCUIT SECTION 1

U1 Main PC board(NAAF-7336-1B/1C/1D/1E)			U1 Main PC board(NAAF-7336-1B/1C/1D/1E)		
REF. NO.	PART NO	DESCRIPTION	REF. NO.	PART NO	DESCRIPTION
	ICs			Capacitors	
Q351	22241221R2	TC9164AF	C352,C937	354761019	100uF,35V,Elect.
Q933	222780055JRC or 222780055MIT or 222780055NEC	78M05(NJM78M05FA) 78M05L(M5F78M05L) 78M05HF(MPC78M05HF)	C511,C611 C781 C938,C939	354741009 354744709 354781019	10uF,16V,Elect. 47uF,16V,Elect. 100uF,50V,Elect.
Q934	222780565JRC	78M56(NJM78M56FA)	C942,C943 C945,C947 C933,C934 C936	354742219 354741009 393353327 393352227	200uF,16V,Elect. 10uF,16V,Elect. 3300uF,25V,Elect. 3300uF,25V,Elect.
	Transistors			Resistors	
Q508,Q608	2215864 or 2212115 or 2213284 or 2213285	KTC3199-GR 2SC2458-GR 2SC1740S-R 2SC1740S-S	C512,C612 C931,C932 C512,C612 C931,C932	374724734 374723344 374724734 374723344	ECQ-V50V-473J,Plastic film ECQ-V50V-334J,Plastic film ECQ-V50V-473J,Plastic film ECQ-V50V-334J,Plastic film
Q509,Q609	2216563 or 2211654 or 2216564	KTC1027-O 2SC2235-Y KTC1027-Y	R521,R621 R932,R938 R936,R937 R939	443521014 442521004 442723314 442625604	100ohm +/-5%,1/2W,Metal oxide 10ohm +/-5%,1/2W,Metal oxide 330ohm +/-5%,2W,Metal oxide 56ohm +/-5%,1W,Metal oxide
Q510,Q610	2216573 or 2211644 or 2216574	KTA1023-O 2SA965-Y KTA1023-Y	R522,R622 R523,R623 R931 R940 R522,R622	4500027 453530824 453534794 452530474 4800071	0.22ohm +/-5%,2W,Metal plate 8.2ohm +/-5%,1/2W,Metal 0.47ohm +/-5%,1/2W,Metal 4.7ohm +/-5%,1/2W,Metal RSS2WK-0.22,Cement resistor
Q781	2216185R2 or 2214374R2	KTA1504-GR 2SA1162-Y			
Q782	2216175R2 or 2213143R2 or 2213144R2 or 2213145R2 or 2216173R2 or 2216174R2	KTC3875-GR 2SC2712-O 2SC2712-Y 2SC2712-GR KTC3875-O KTC3875-Y			
Q932	2215975 or 2211455	KTA1266-GR 2SA1015-GR			
	Diodes			Plugs	
D931	22380271 or 22380022 or 22380285	D3SBA20 RBV402 RS403M	P101A P102A,P103A P304A,P501A P305 P502A,P503A	25055709 25055702 25055708 25055038 25055804	NPLG-13P665 NPLG-6P658 NPLG-12P664 NPLG-2P29 NPLG-4P760
D933-D939	22380260 or 22380032 or 22380035	RL1N4003 1SR139-100 GP104003E			
D934,D944	22380032	1SR139-100			
D943,D944	22380260 or 22380035	RL1N4003 GP104003E			
D781	223234R2 or 223269R2	1SS352,Chip 1SS355,Chip			
D940	224492700R2 or 224552700R2	UDZ27B,Zener UDZS27B,Zener			
D941,D942	224490390R2 or 224550390R2 or	UDZ3.9B,Zener UDZS3.9B,Zener			
D945-D948	224490390R2 or 224550390R2	UDZ3.9B,Zener UDZS3.9B,Zener			
				Sockets	
			JL501B,JL502B JL931B JL932B P701A P303A	25050269 25050272 25050268 25052223 2009990697UL	NSCT-5P97 NSCT-8P100 NSCT-4P96 NSCT-27P2120 NSAS-6P0972
				Jacks	
			P301,P302	25045575 or 25045303	NPJ-4PDRW389 NPJ-4PDBL162
				Retainer	
			E931	27141059	Retainer

Note
 <PP>.....European model only
 <DT>.....120V model only
 <GT,GR>...220-230V model only

THE COMPONENTS IDENTIFIED BY MARK Δ ARE
 CRITICAL FOR RISK OF FIRE AND ELECTRIC SHOCK.
 REPLACE ONLY WITH PART NUMBER SPECIFIED.

PARTS LIST

CIRCUIT SECTION 2

U2 Acoustic PC board(NAAF-7337-1B/1C/1D/1E)			U3 Driver PC board(NAAF-7338-1B/1C/1D/1E)			
REF. NO.	PART NO	DESCRIPTION	REF. NO.	PART NO	DESCRIPTION	
	ICs			Transistors		
Q361,Q461	22241383R2 or 22240489R1NE	NJM4565M-D MPC4570G2-T1(MST)	Q501,Q502	2216154R2 or 2216153R2	2SC1622A(D18) 2SC1622A(D17)	
Q381	22240981R2	TC9162AF	Q503,Q603	2216175R2 or 2213143R2 or 2213144R2 or 2213145R2 or	KTC3875-GR 2SC2712-O 2SC2712-Y 2SC2712-GR	
Q362,Q462	2215510R2	RN1443		2216173R2 or 2216174R2	KTC3875-O KTC3875-Y	
Q382	2216220R2 or 2214530R2	KRA102S RN2402		2215975 or 2211455	KTA1266-GR 2SA1015-GR	
	Capacitors			Diodes		
C361,C367	354742209	22uF,16V,Elect.	Q504-Q506	2215985 or 2211255	1SS352,Chip 1SS355,Chip 1SS352,Chip 1SS355,Chip	
C369,C385	354780109	1uF,50V,Elect.	Q507,Q607	2216154R2 or 2216153R2	UDZ5.6B UDZS5.6B	
C382	354761019	100uF,35V,Elect.		2215975 or 2211455	2SA1015-GR	
C386,C387	354742219	220uF,16V,Elect.		Capacitors		
C461,C467	354742209	22uF,16V,Elect.	Q601,Q602	354742209 354742219	22uF,16V,Elect. 220uF,16V,Elect.	
C469	354780109	1uF,50V,Elect.		C509,C609	354741009	
C365,C366	374725634	ECQ-V50V-563J,Plastic film	Q604-Q606	354761019	100uF,35V,Elect.	
C368,C468	374721534	ECQ-B50V-153J,Plastic film		C5621,C562	354742209	
C370,C470	374721544	ECQ-V50V-154J,Plastic film		C601,C604	354742209	
C465,C466	374725634	ECQ-V50V-563J,Plastic film	D501,D503		22uF,16V,Elect.	
	Resistors		D501,D503	223234R2 or 223269R2	390hm +/-5%,1/2W,Metal oxide 330hm +/-5%,1/2W,Metal oxide	
R386,R387	443521004	10ohm +/-5%,1/2W,Metal oxide	D601,D603	223234R2 or 223269R2	390hm +/-5%,1/2W,Metal oxide 220hm +/-5%,1/2W,Metal oxide	
R381	5104383	N16RGL100KBT20F,Variable		224490560R2 or 224550560R2	390hm +/-5%,1/2W,Metal oxide	
	Plug		D502,D602	224490560R2 or 224550560R2	390hm +/-5%,1/2W,Metal oxide	
P303B	25055441	NPLG-3P423		Resistors		
	Shield plate			R512,R513	443523904	
R381A	27150477	(VOL)	C501,C504	443523904	390hm +/-5%,1/2W,Metal oxide	
	Socket		C505,C605	443523904	390hm +/-5%,1/2W,Metal oxide	
P304B	25051237	NSCT-12P1027	C509,C609	443522204	220hm +/-5%,1/2W,Metal oxide	
			C5621,C562	443523904	390hm +/-5%,1/2W,Metal oxide	
			C601,C604	443523904	390hm +/-5%,1/2W,Metal oxide	
				Sockets		
			R613,R615	443523904	390hm +/-5%,1/2W,Metal oxide	
			P501B	25051237	NSCT-12P1027	
			P502B,P503B	25051526	NSCT-4P1313	
				U4 Headphone PC board(NAETC-7339-1B/1C/1D/1E)		
				REF. NO.	PART NO	DESCRIPTION
				R528,R628	443523914	390ohm +/-5%,1/2W,Metal oxide
				P504	25045396	LGT1516-0101
				JL501A	25051109	NSCT-5P896

Note
<PP>.....European model only
<DT>.....120V model only
<GT,GR>...220-230V model only
THE COMPONENTS IDENTIFIED BY MARK ARE CRITICAL FOR RISK OF FIRE AND ELECTRIC SHOCK. REPLACE ONLY WITH PART NUMBER SPECIFIED.

PARTS LIST CIRCUIT SECTION 3

U5 Connection PC board(NAETC-7340-1B/1C/1D/1E)			U8 Microprocessor PC board(NADG-7343-1B/1C/1D/1E)		
REF. NO.	PART NO	DESCRIPTION	REF. NO.	PART NO	DESCRIPTION
ICs			ICs		
Q951	222780125JRC or 222780125MIT or 222780125NEC	NJM78M12FA M5F78M12L MPC78M12HF	Q701	22241712R3	MPD78045FGF-133-3B9
Q101	2216175R2 or 2213143R2 or 2213144R2 or 2213145R2 or 2216173R2 or 2216174R2	KTC3875-GR<PP> 2SC2712-O<PP> 2SC2712-Y<PP> 2SC2712-GR<PP> KTC3875-O<PP> KTC3875-Y<PP>	Q702	22240239	TA7291S
Capacitors			Q704	22241297R2	BU1923F<PP>
C952	354741009	10uF,16V,Elect.	Transistors		
C104	354780339	3.3uF,50V,Elect.	Q703	2216210R2 or 2214490R2	KRC104S RN1404
Resistor			Q706	2216230R2 or 2214540R2	KRA103S RN2403
R951	452530474	4.7ohm +/-5%,1/2W,Metal oxide	Diodes		
Plug			D701,D702	22380260 or 22380032 or 22380035	RL1N4003 1SR139-100 GP104003E
P104A	25055707	NPLG-11P663	D703,D704	223234R2 or 223269R2	1SS352,Chip 1SS355,Chip
Sockets			D705,D706	224490510R2 or 224550510R2	UDZ5.1B,Zener UDZS5.1B,Zener
P102B,P103B	25051231	NSCT-6P1021	Oscillators		
P101B	25051238	NSCT-13P1028	X701	3010261	HC-49/U03 4.19M10P
P105A	25052248	NSCT-15P2145	X702	3010203	AF6146CG<PP>
U6 Input/Output PC board(NAETC-7341-1B/1C/1D/1E)			Coils		
REF. NO.	PART NO	DESCRIPTION	L701	231237K220R2	NCH-1477
Jacks			L702	231237K220R2	NCH-1477<PP>
P311	25045571 or 25045300	NPJ-6PDRW386 NPJ-6PDBL159	Capacitors		
P781	25045504	NPJ-1PDBL319	C708	3000120	FMC0H104Z,EDL
Socket			C703	353744709	47uF,16V,Elect.
P104B	25051236	NSCT-11P1026	C705	353780109	1uF,50V,Elect.
U7 Display PC board(NADIS-7342-1B/1C/1D/1E)			C711	354780339	3.3uF,50V,Elect.
REF. NO.	PART NO	DESCRIPTION	C715	353781009	10uF,50V,Elect.
FL. Tube			C716	354721019	100uF,6.3V,Elect.
Q705	212223	HNA-09SS27T	C721,C724	354721019	100uF,6.3V,Elect.<PP>
LES			C722	374725614	ECQ-B50V-561J<PP>
D707	225338	SLR-332VR	C707	3060031	NTC-45P27
D708	225340	SLR-332DU	Socket		
Remote sensors			P701B	25052223	NSCT-27P2120
U701	241335 or 241341	SPS-444-1 SPS-444-1-E1	Wire holders		
Capacitor			JL701A,JL702A	25051094	NSCT-10P881
C726	353741009	10uF,16V,Elect.	JL703A	25051093	NSCT-9P880
Push switch			JL704A	25051094	NSCT-10P881
S702-S707	25035699	NPS-111-S662	Note		
Rotary Encoder			<PP>.....European model only		
S701	25065622	EC11101200	<DT>.....120V model only		
Wire holder			<GT,GR>...220-230V model only		
JL703B	25051093	NSCT-9P880	THE COMPONENTS IDENTIFIED BY MARK  ARE CRITICAL FOR RISK OF FIRE AND ELECTRIC SHOCK. REPLACE ONLY WITH PART NUMBER SPECIFIED.		
JL701B,JL702B	25051094	NSCT-10P881			

PARTS LIST

CIRCUIT PARTS 4

U9		
Power supply PC board(NAPS-7344-1B/1C/1D/1E)		
REF. NO.	PART NO	DESCRIPTION
Transistors		
Q901	2215830 or 2213640	KRC105M DTC123JS
Diodes		
D902-D905	22380260 or 22380032 or 22380035	RL1N4003 1SR139-100 GP104003E
D901,D906	223234R2 or 223269R2	1SS352,Chip 1SS355,Chip
D907	223234R2 or 223269R2	1SS352,Chip 1SS355,Chip
D908	224490510R2 or 224550510R2	UDZ5.1B,Zener UDZS5.1B,Zener
Coils		
L571,L671	231176S	S-1.3C
Capacitors		
C904	354742219	220uF,16V,Elect.
C905	354741009	10uF,16V,Elect.
C901	3500196	RE275V-103M,Plastic film
C571,C671	374721034	ECQ-B50V-103J,Plastic
C573	374724734	ECQ-V50V-473J,Plastic
Resistors		
R901	443521004	82ohm +/-5%,1/2W,Metal oxide<PP>
R906	443528204	10ohm +/-5%,1/2W,Metal oxide
R571,R671	453530564	5.6ohm +/-5%,1/2W,Metal
R901	453530564	5.6ohm +/-5%,1/2W,Metal<DT,GR,GT>
R907	431533355	⚠ RC1/2GFKUL-3.3M,Solid<DT>
Transformer		
T902	2301464	⚠ NPT-1398D<DT>
	2301465	⚠ NPT-1398G<GR,GT>
	2301539	⚠ NPT-1398P<PP>
Relays		
RL901	25065603 or 25065601	⚠ NRL-1P5A-DC9-152 ⚠ NRL-1P5A-DC9-150
Terminal		
P571	25060286	NTM-4PDML217
Jack		
P572	25045567	NPJ-1PDBL382
Plug		
P901A	25055676	NPLG-2P632
Fuse holders		
F901A,F901B	25052133	⚠ NSCT-1P2031
Wire holders		
JL502A	25051109	NSCT-5P896
JL931A	25051112	NSCT-8P899
JL932A	25051108	NSCT-4P895
Labels		
F901C	29363040	T315mAL250V<PP>
	29363040	T315mAL250V<GR>
	29363040	T315mAL250V<GT>
	29360667	LABEL(F)<DT>

Note
<PP>.....European model only
<DT>.....120V model only
<GT,GR>...220-230V model only

THE COMPONENTS IDENTIFIED BY MARK ⚠ ARE CRITICAL FOR RISK OF FIRE AND ELECTRIC SHOCK. REPLACE ONLY WITH PART NUMBER SPECIFIED.

FL.TUBE

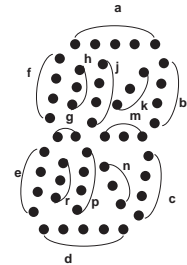
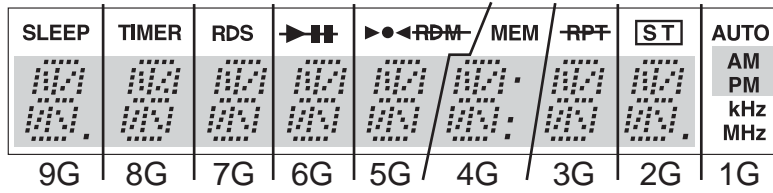

	9G	8G	7G	6G	5G	4G	3G	2G	1G
P1	a	a	a	a	a	a	a	a	-
P2	i	i	i	i	i	i	i	i	-
P3	h	h	h	h	h	h	h	h	-
P4	k	k	k	k	k	k	k	k	-
P5	b	b	b	b	b	b	b	b	-
P6	f	f	f	f	f	f	f	f	-
P7	q	q	q	q	q	q	q	q	-
P8	m	m	m	m	m	m	m	m	PM
P9	c	c	c	c	c	c	c	c	AM
P10	e	e	e	e	e	e	e	e	-
P11	n	n	n	n	n	n	n	n	-
P12	r	r	r	r	r	r	r	r	MHz
P13	p	p	p	p	p	p	p	p	kHz
P14	d	d	d	d	d	d	d	d	-
P15	SLEEP	TIMER	RDS	▶	RDM	MEM	RPT	ST	AUTO
P16	Dp	-	-		▶●◀	Dp	-	Dp	-
P17	-	-	-	-	-	col	-	-	-

MICROPROCESSOR CONNECTION DIAGRAM

1

2

3

4

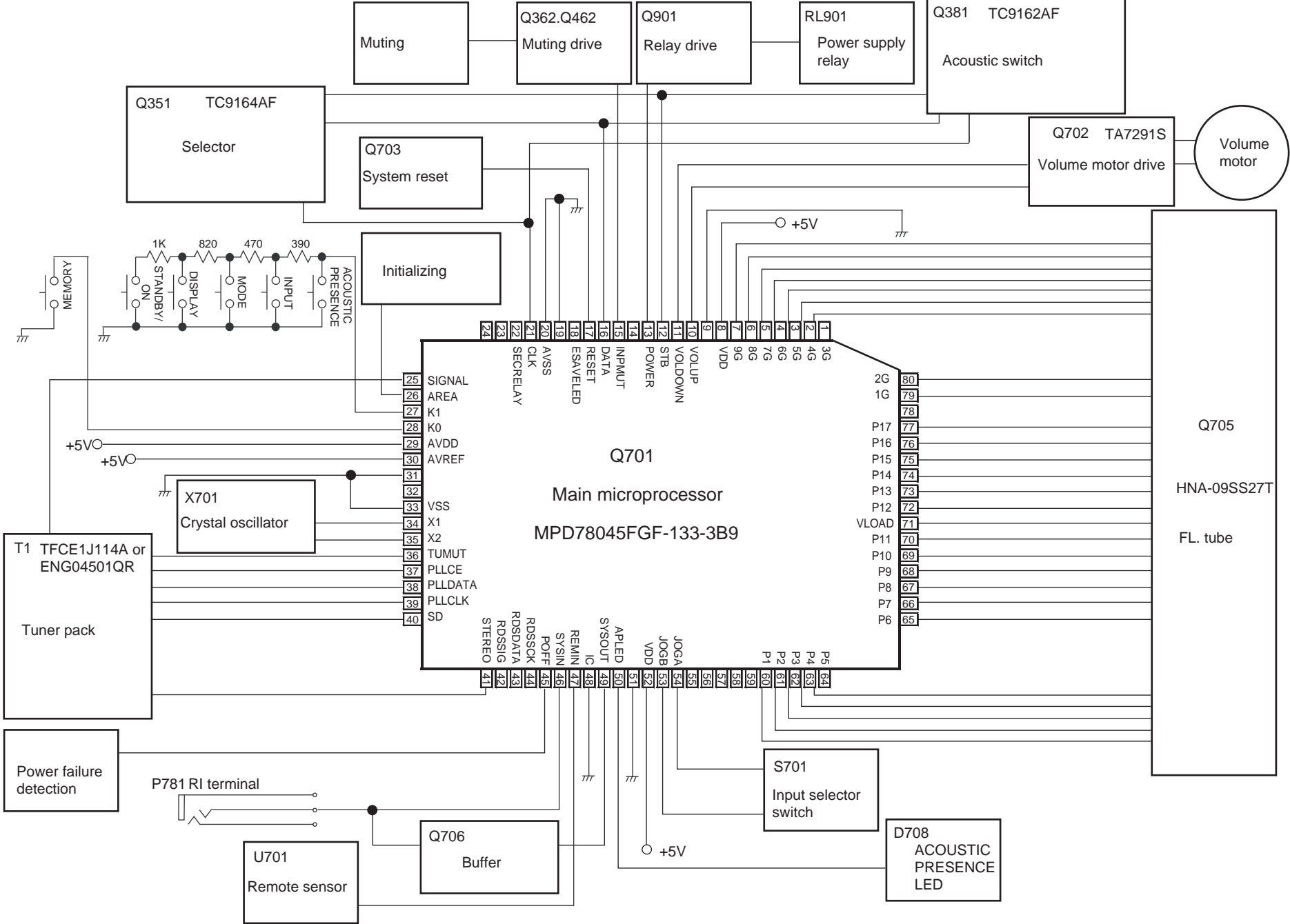

MICROPROCESSOR CONNECTION DIAGRAM

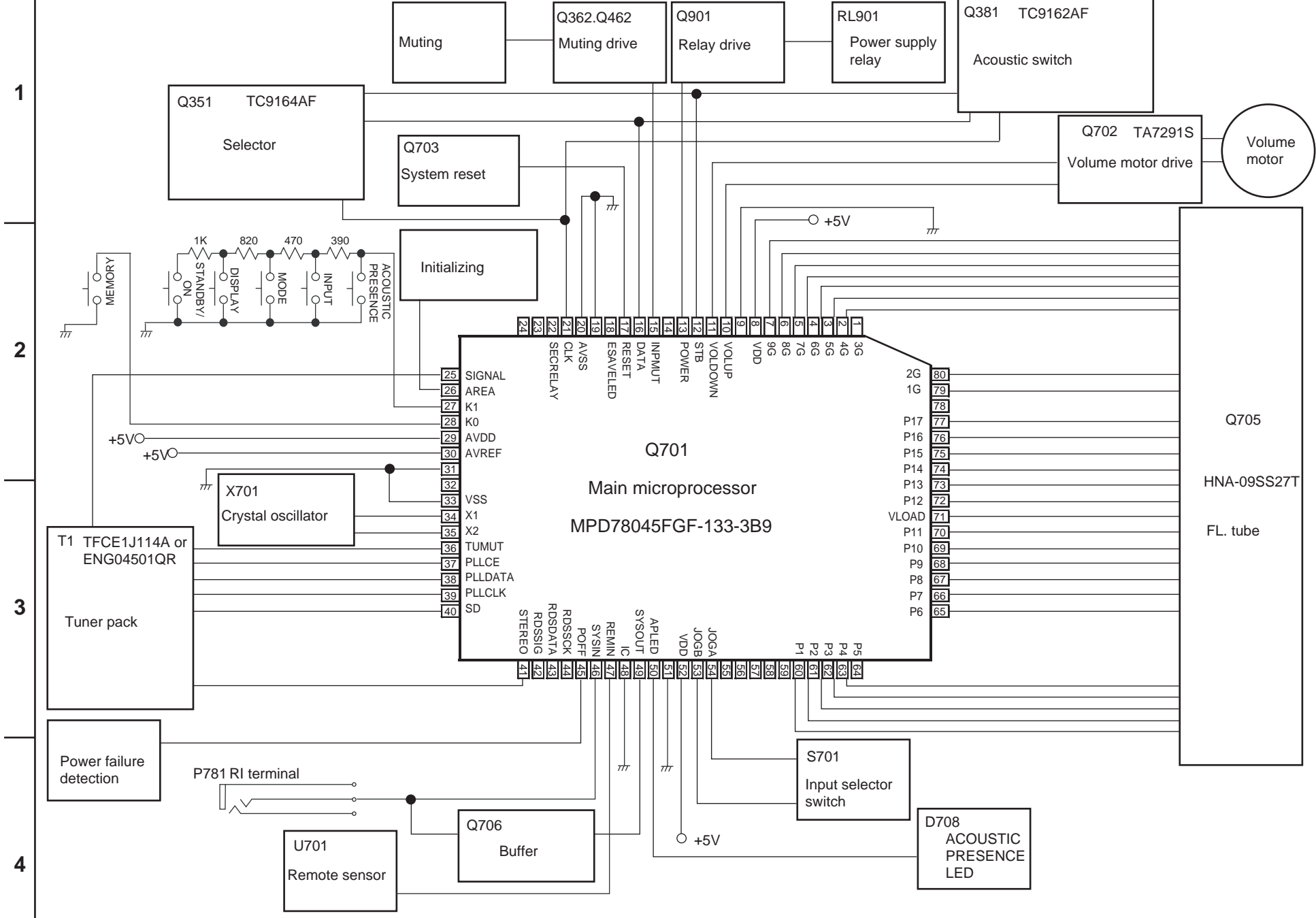

ADJUSTMENT PROCEDURES

Adjustment of clock frequency

1. Connect the frequency counter between the terminal P305 and Chassis.
2. Press and hold down the MEMORY button, then press the DISPLAY button.(All segments on FL tube light on)
3. Adjust the trimmer capacitor C707 so that the reading of frequency counter becomes 524.288 kHz.

Destination check

Press and hold down "MEMORY"key at standby,then press "INPUT"key .

Destination	Indication
MJJ	JJ
MPP	PP
MDT,MGT,MGR	DT,GT
NO GOOD	AREA NG

Version indication of microprocessor

Press and hold down "ACOUSTIC PRESENCE"key at standby,then press "INPUT"key.

Initialize

- 1.Press and hold down "MEMORY"key at standby,then press "DISPLAY"key.
(The all segments on the FL. tube light on)
- 2.Press "STANDBY/ON"key.

Shipping position

Turn the volume to a minimam position.

PACKING VIEW

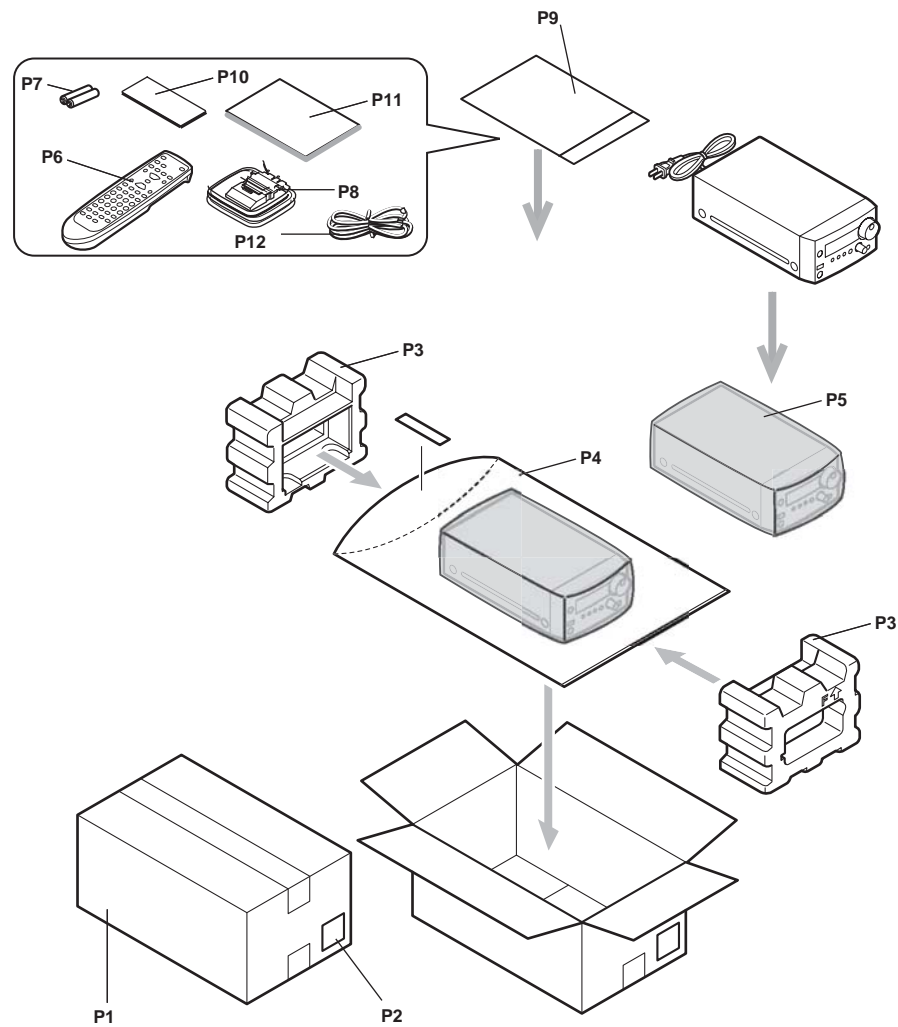

PARTS LIST

REF. NO.	PART NO.	DESCRIPTION
P1	29053813	Carton <PP>
	29053812	Carton <DT,GT>
	29053814A	Carton <GR>
P2	29362962A	EAN Label
P3	29092008	Pad ass'y
P4	29100123C	430x550,Polybag
P5	29095906	Sheet
P6	24140466A	RC-466S,Remote controller
P7	3010154	UM-3,Battery
P8	232140	NMA-3057,AM 100p antenna
P9	29100097-1A	350x250,Polybag
P11	29343214A	Instruction manual,E
	29343215A	Instruction manual,U3GDSW<PP>
	29343216A	Instruction manual,U3FSI<PP>
	29343218A	Instruction manual,CT<DT,GR,GT>
	29343233A	Instruction manual,CS<GR>
P12	292115	FM Antenna ass'y
P13	25065462	YAE21-0237,FM antenna adapter

ONKYO CORPORATION

Sales & Product Planning Div. : 2-1, Nisshin-cho, Neyagawa-shi, OSAKA 572-8540, JAPAN
Tel: 072-831-8111 Fax: 072-833-5222

ONKYO EUROPE ELECTRONICS GmbH

Industriestrasse 20, 82110 Germering, GERMANY
Tel: 089-849-320 Fax: 089-849-3265 E-mail: info@onkyo.de

ONKYO CHINA LIMITED

Units 2102-2107, Metroplaza Tower I, 223 Hing Fong Road, Kwai Chung,
N.T., HONG KONG Tel: 852-2429-3118 Fax: 852-2428-9039